

Trivia

School chair

Design — Iiro Viljanen



The Trivia school chair is suitable for children of all sizes as its height can be easily adjusted. The chair is made of solid steel tube and laminate and is particularly durable.



MATERIAL DESCRIPTION:

Frame and base: grey, white or black

Seat and backrest: white or birch laminate

Plastic or felt glides

PRODUCT CODE NUMBER:

OT131

ADJUSTMENTS:

Sitting height 36 – 51 cm (6 steps).

WEIGHT:

6.5 kg

Dimensional drawing:

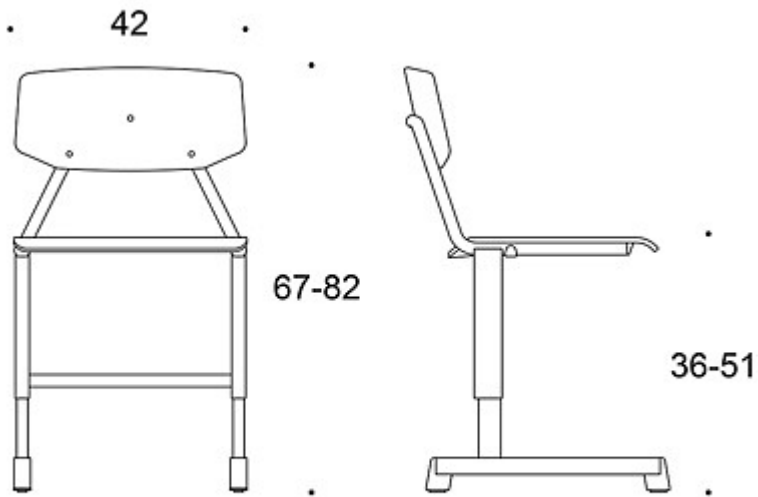

OT131