

Mute Flow PET Felt Acoustic Panel Installation Guide

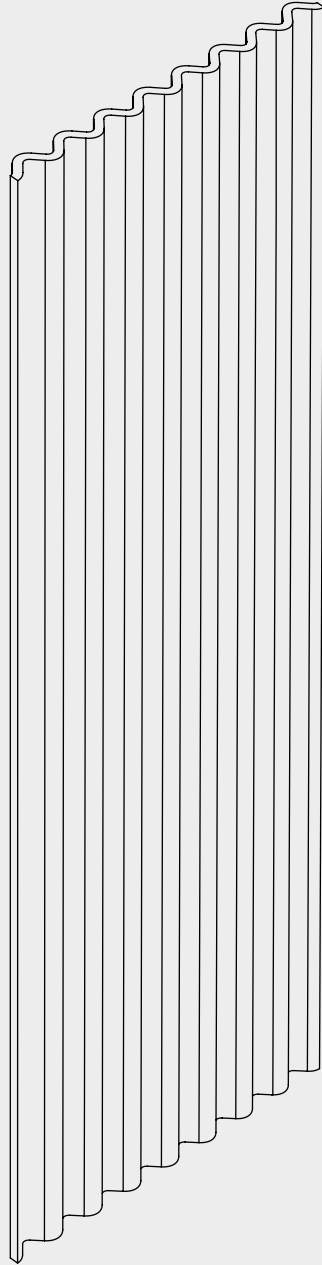

DeVorm

Tools

! If you install the Mute panels with a fire retardant treatment, make sure to mount them on a non-combustible background and / or use non-combustible mounting materials.

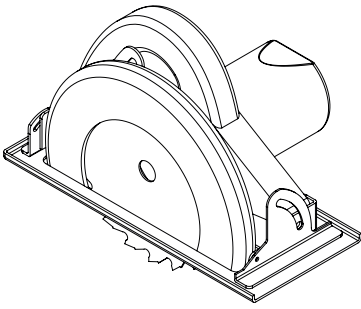

Circular saw

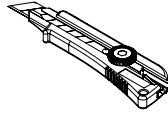

Snap-off blade cutter

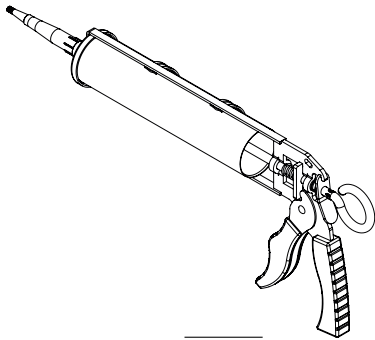

Glue gun

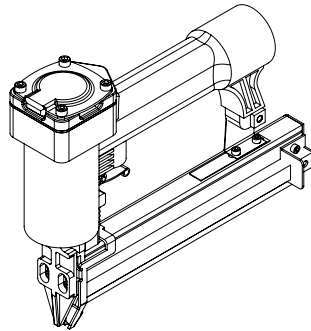

Nail gun

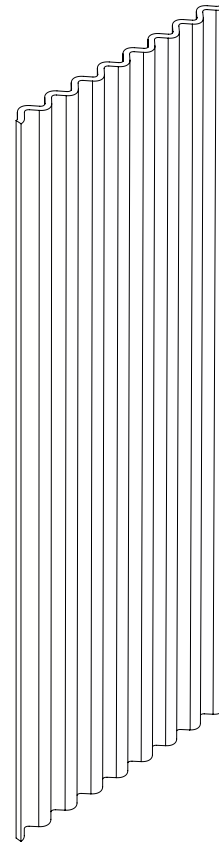

Mute Flow panel

For the best result, avoid cutting the Mute Flow panels in a curve.

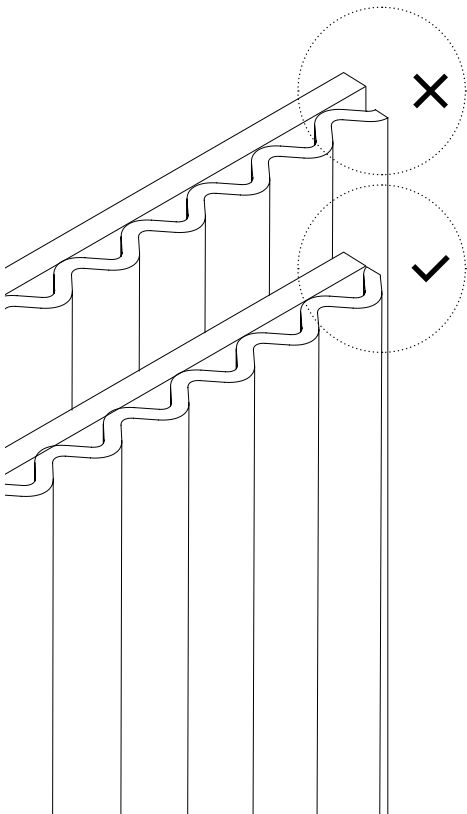

1 Measure the surface that you want to cover with Mute Flow panels. Cut the panels in the right sizes with a circular saw or a knife.

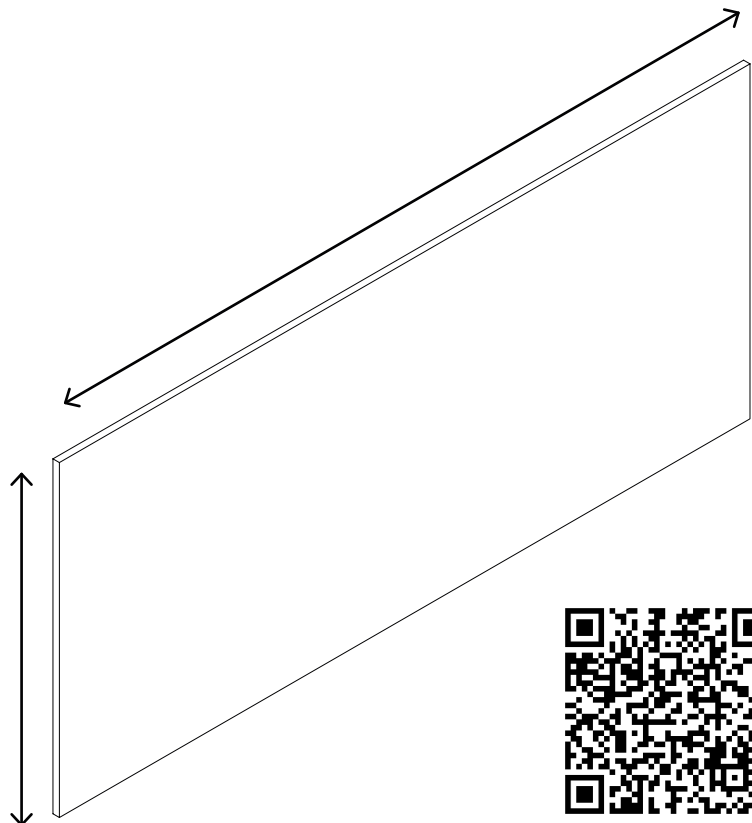

! For more information, check our video instructions.

Fix Mute Flow with glue gun

- 1 When you made sure the surface is clean and flat, apply the adhesive to the panel, following the adhesive manufacturer instructions. Distribute the glue evenly on the parts of the panel that will touch the wall.

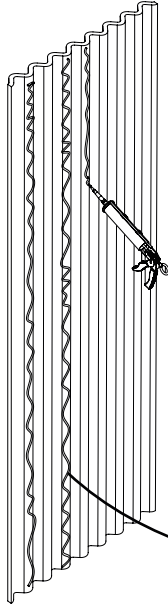

- 2 Start applying the panel from the bottom and place the panel aligned on the wall.

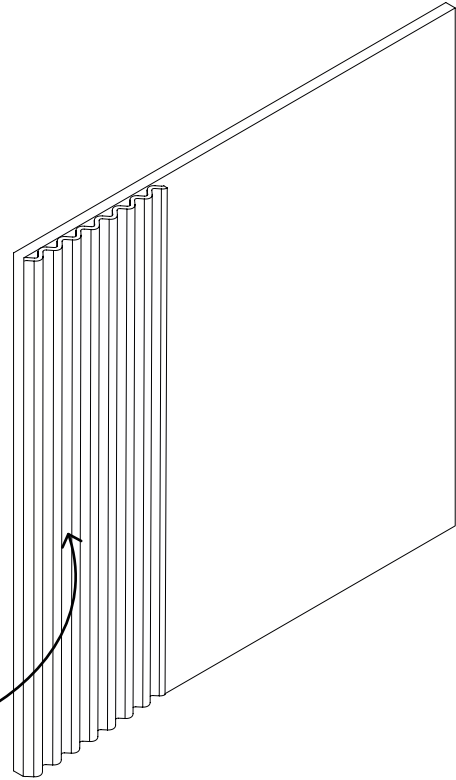

- 3 Press the panel firmly against the surface, make sure that the corners and edges are properly attached.

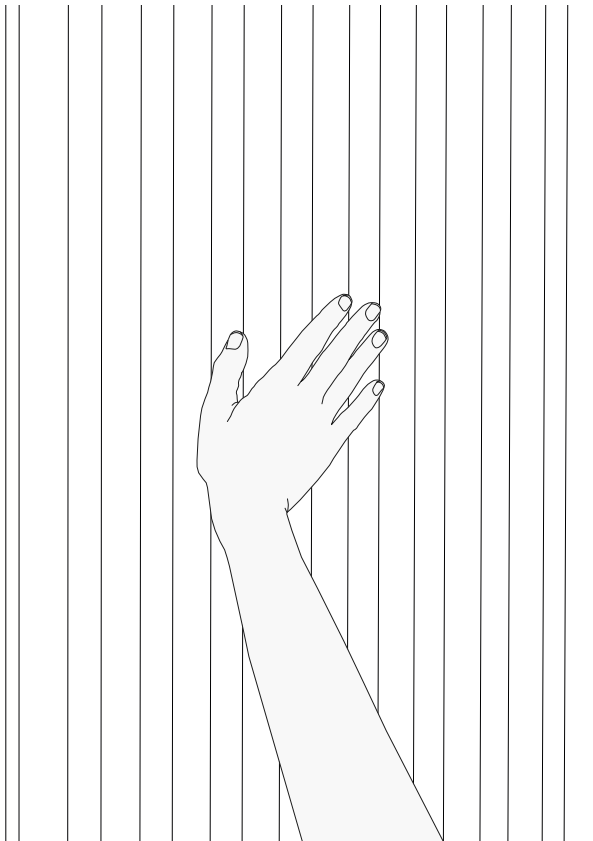

- 4 Allow the adhesive to cure. The curing time may vary, follow the adhesive manufacturer recommendations.

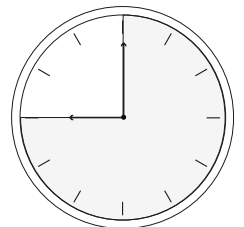
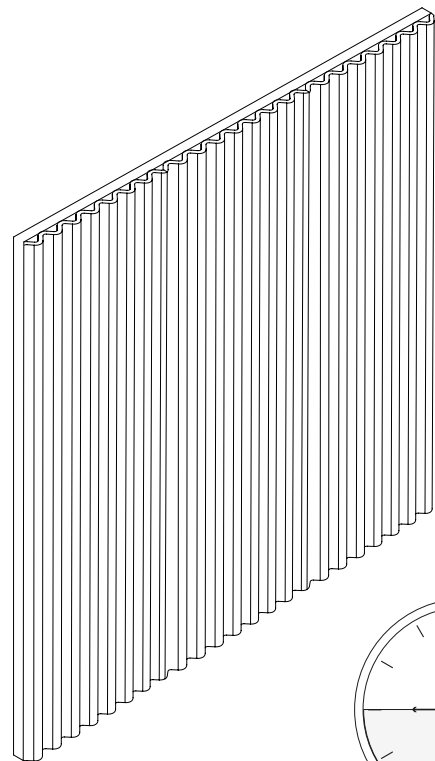

Fix Mute Flow with nail gun

- 1 Prepare a wooden framework and make sure the frame is leveled.

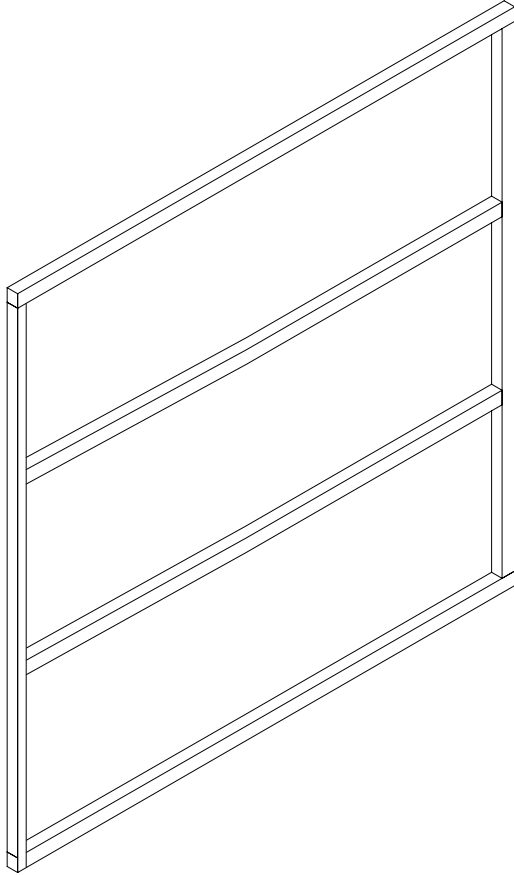

- 2 The pressure of a pneumatic nailer tool must not be set too high, otherwise the staples or nails can go through the material.

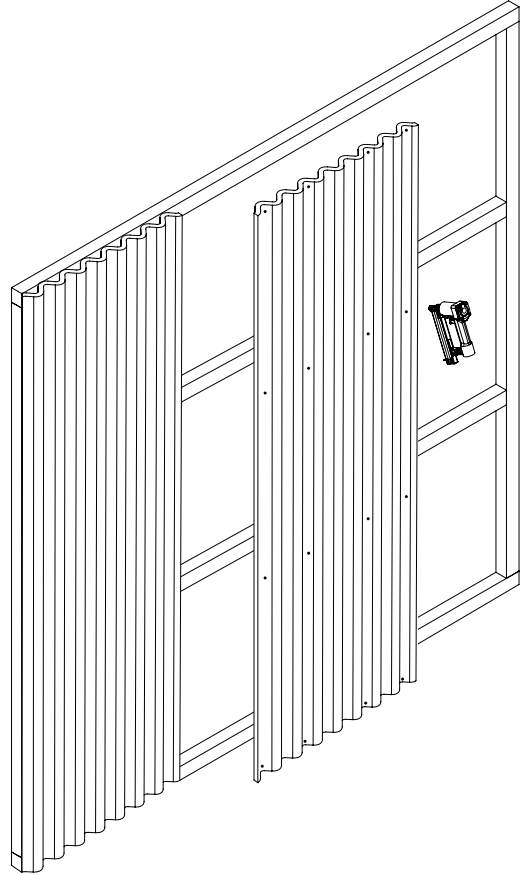

- 3 For a better grip of the headless nail, the nails can be applied at an angle of approximately 45° .

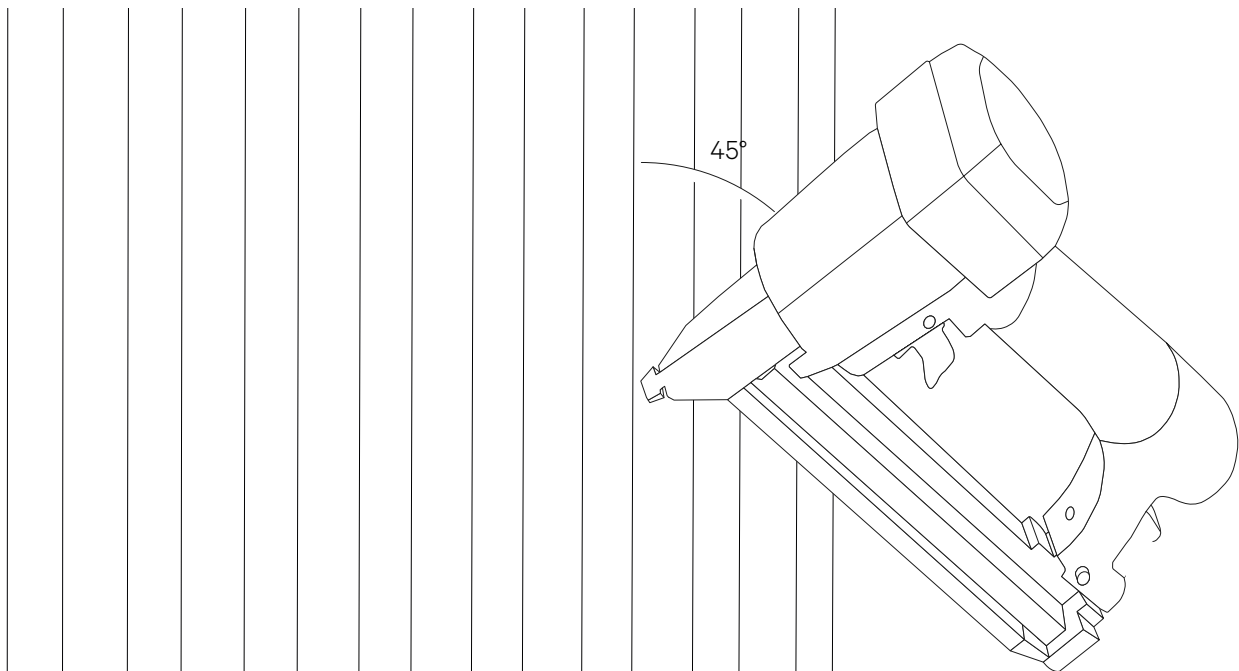

We create interior products by today's standards.

De Vorm is established in a new era, we develop products by the standards of today. This means we produce efficiently, use the full lifecycle of products and eventually give them a new life.

Our emphasis lies on making a product that works, by setting a variety of conditions; it should be legible, accessible, but also environmental friendly and aesthetically perfectly in balance.

We like a product because of its functionality.

A good product makes life easier — by helping us function better throughout the day. We firmly believe that the beauty of a design lies in the sum of its functions. That is what makes it a complete product.

We continuously raise the bar.

From the very first sketches we already start searching, combining and developing new techniques to find new possibilities to innovate. Our design process is infused with technical development; techniques result in aesthetic features and the other way round.

Leemansweg 45
6827 BX Arnhem
The Netherlands

T +31(0) 268 200 360
E info@devorm.nl
W www.devorm.nl