

# Wilkhahn

Insit. 780 range.





## Insit

The design of contemporary office and contract furniture needs to convey a distinct corporate identity and foster collaboration and a feeling of well-being. All three aspects are reflected in the Insit upholstered furniture range. Whether as a standalone piece or linked to form a sectional group, the characteristic design with its stylishly modelled frame, flat upholstery, and distinctive backrest positioned on top is a symbol of collaborative working with a feel-good flair.

With a light and airy design, the firm upholstery guarantees agile comfort and, at a seating height of 45 cm (17¼ inches), enables people to hold discussions, work, or eat and drink at standard table heights. And last but not least, Insit's variety of models and configurations makes it a multipurpose, attractive eye-catcher that allows office workers to sit, interact, and work together.

Design: Wolfgang C.R. Mezger

The bench with its low backrest and alternating seating direction can be used with the Insit Screen rear and side panels as a room divider to offer visual and acoustic privacy just like the bench with a high backrest and side table. Models 783/56 and 782/5 with rear panel 781/1, L-shaped screen on the right 781/11 and side table 780/11.



The sculptural design is particularly distinctive in the standalone benches with backrests. While the slimline upholstery has clear contours, the backrest's molded and subtly organic shape promises superior comfort. The three-seaters are especially inviting and offer a multitude of sitting options. Just like a chaise longue, they have a shorter backrest that curves around on one end and an edge that protrudes over the frame on the other. The 45° angle of the backrest encourages the person seated there to talk to their neighbor, while the end without a backrest can be sat on from all sides.



The range's diverse formats and models guarantee the furniture can be used in lots of places in today's offices: from lobbies, co-working spaces, areas in the middle of rooms to meeting spaces and quiet zones to cafés and restaurants. The distinctive design language becomes the common denominator and combines diversity with a clear identity.



Upholstered bench with backrest, 60° model 783/60 (concave and convex) with tables 780/1, benches model 782/5 and bench without backrest model 783/6 with table model 780/9



Models 782/51 right and models 782/51 left, object: town hall Salem, Germany, photo: Anja Koehler, andereart.de



Models 782/51 right and models 782/51 left, object: town hall Salem, Germany, photo: Anja Koehler, andereart.de



Insit with a high backrest and open end at the side, model 782/51, partial privacy with an L-shaped screen on the right, model 781/11, covered with Hush Stripe 40 fabric.  
In the foreground on the left: Confair folding table, model 440/00, design: Andreas Störko, with Pep swivel-mounted conference chairs, model 227/33, design: Wilkhahn.





Model 782/52 left and model 782/52 right, object: Neue Mitte Remseck, photo: Rolf Schwarz, Fotodesign, Ludwigsburg



Model 782/52 left and model 782/52 right, object: Neue Mitte Remseck, photo: Rolf Schwarz, Fotodesign, Ludwigsburg



Model 783/5 with Insit U-shaped screen 781/10, rectangular table 780/9 and Occo Conference, model 224/53, design: jehs+laub



Two benches with high backrests, model 782/5, and C-shaped screen 781/20, covered with Hush Stripe 40, and an Aline table, model 237/00, design: Andreas Störiko.  
In the foreground: Neos cantilever chair, model 183/5, design: wiege, at an Aline table.



Corner benches, model 782/90, at Graph tables, model 300/00, with Occo conference chairs, model 224/33, in the background: Occo high table, model 222/81 with Occo bar stools, model 223/21, all designed by jehs+laub.

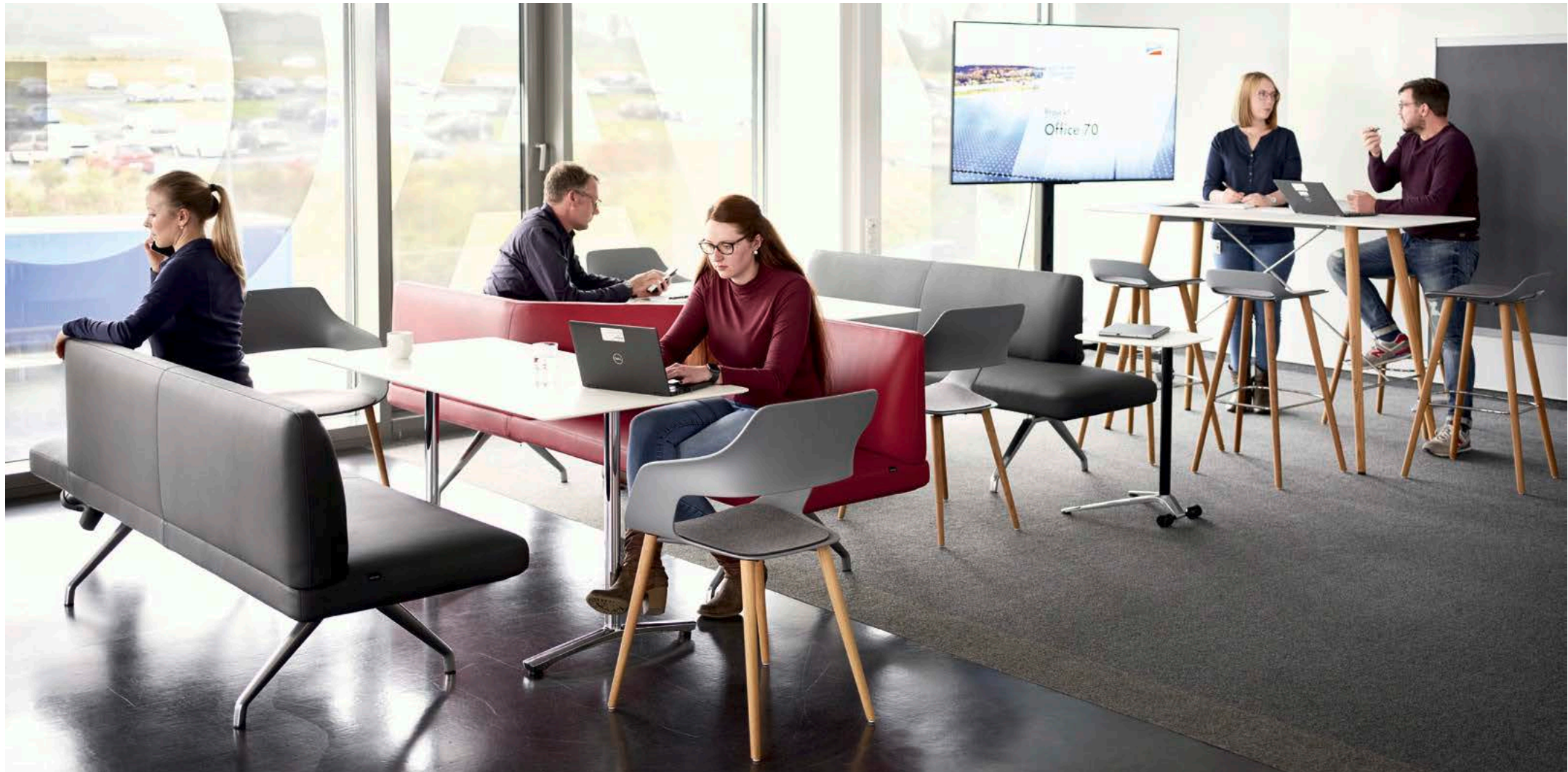

Models 782/81 and 783/56 with Aline table 237/00, design: Andreas Störiko, Occo chairs 222/20, Occo bar stools 223/21, Occo high table 222/81, design: jehs+laub and Confair side table 441/2, design: wiege, Fritz Frenckler, Justus Kolberg, photo: Frank Schinski.

# Insit. 780 range. Models and dimensions.

## Wilkhahn



782/5



782/5



783/5

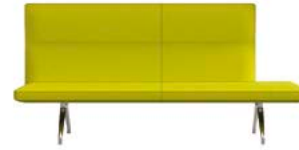

783/51



782/52



783/5



782/6



783/6



782/52



783/52



782/51



782/51



782/51



783/55



783/60



782/51



783/51



783/51



783/90



783/51



783/52



783/56



783/90

The standard models already allow a virtually endless number of combinations. The range of two-, two-and-a-half, and three-seaters measuring 165 cm to 240 cm (65" to 94½") in width and 65 cm (25½") in depth includes benches that are straight, radial, or linked at a 90° angle at the corner and come with straight or sloping backrests on one or both sides. Some models feature extended seats to offer space at the ends, and the three-seater is even available with a backrest that changes direction to turn it into a two-and-a-half seater. As a standard, the straight models are also available with high backrests if more privacy's required. By contrast, benches without backrests invite people to come and sit on all sides or to lie down – for example in quiet areas.

# Insit. 780 range. Overview of table models.

# Wilkhahn

## Overview of table models



The range of benches is also complemented by matching stand-alone tables. The frames of the lounge tables, which are 38 cm in height and 70 × 140 cm (27½" × 55½") in size, are the same as the frames on the benches. All tables for working, eating and drinking, or holding meetings at come in 73 cm high square (70 × 70 cm (27½" × 27½"), 140 × 140 cm (55½" × 55½")) or round (70 cm (27½") diameter) versions or as rectangular pedestal tables (70 × 140 cm (27½" × 55½"), 70 × 175 cm (27½" × 68¾")), and all have sturdy steel frames.

## Connecting tables



Thanks to inline connectors with screws, the standalone benches can be linked directly or by using connecting leaves or corner tables to reconfigure whole groups of sectional seating that people can sit and work on however they like. There are also side tables and, when Insit Screen side- and rear-panels are fitted, extra shelves and corner writing ledges too.



# Insit. 780 range. Product versions.

# Wilkhahn



Evida fabric is particularly easy to care for and, in addition to the Ökotex 100 standard, also meets hygiene requirements for medical products.



Hush Stripe 40 is a fabric only available for Insit Screen and its embossed stripes spaced 4 cm (1 $\frac{5}{8}$ " ) apart, lend the item an elegant look.

## Bench upholstery materials

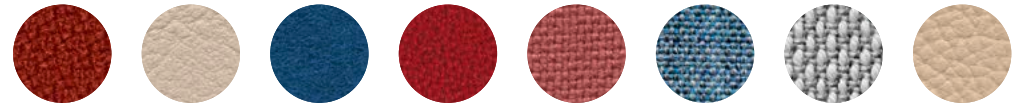

54 Pitch | 58 Evida | 60 Blend | 63 Auris | 66 Lona | 68 Kvadrat Remix 2 | 91 Kvadrat Steelcut Trio 3 | 74 Leather  
You can find all upholstery materials and more colors in our media center.

## Screen upholstery materials

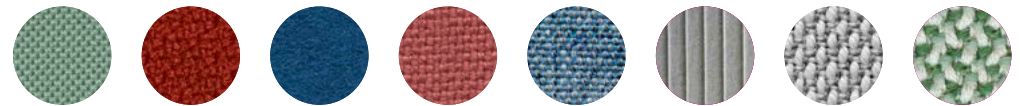

37 Racer | 54 Pitch | 60 Blend | 66 Lona | 68 Kvadrat Remix 2 | 600 Hush Stripe 40 | 91 Kvadrat Steelcut Trio 3 | 92 Credo  
You can find all upholstery materials and more colors in our media center.

The benches' fully upholstered seats and backrests are top quality, hard wearing and designed for frequent use. They consist of solid beech frames with cut foam and cold foam upholstery, which has fleece overlay between the foam and the cover. This makes the furniture pleasant to sit on and protects the foam from mechanical wear and tear.

The digital sample colors differ from the originals.

# Insit. 780 range. Product versions.

# Wilkhahn

## Table top groups



Laminate (single color), soft matte laminate, wood decor laminate, veneer type 1 or 2, black or white HPL (high pressure laminate).  
For additional surfaces, please see our media center.

## Foot section



Coated white, black, or with a silver satin finish, polished aluminum, high-luster polished aluminum

## Disc base with cover and table column



Coated white, black, or with a silver satin finish, bright chrome-plated, brushed stainless steel

## Laminate

The material is made by bonding cellulose and décor paper layers, as well as resin, by applying heat and pressure. This produces an extremely tough surface that comes in a variety of different colors. Laminate is highly recommended for areas where the tables are subject to a lot of wear and tear because they are frequently moved around for example.

## Wood veneers

Natural wood is a living material: in the way it looks and changes over the years. Sometimes more significantly and sometimes more subtly, depending on the type of wood and how light it is. If a more consistent look is preferred, stained surfaces or industrially produced veneer (e.g. mocha) are available.

Coated, polished, and ultra-polished frame surfaces (which are coated and bright chrome-plated in the case of the pedestal side tables), the wide choice of upholstery from Wilkhahn's fabric and leather collection, the HPL, plywood, or MDF tabletops with straight or chamfered edge profiles, and the high-quality laminate or veneered surfaces offer an enormous range of design options to suit all sorts of interior design concepts.

# Insit. 780 range. Edge shapes.

# Wilkhahn

## Edge profiles



Straight plastic edge; straight wood edge; E2 – 5 chamfered wood edge, 12 mm (½");  
E5 – 1 solid-core HPL, edge chamfered, 4 mm (5/32") radius

Straight plastic edge,  
table top 26 mm (1") thick



Straight wood edging  
table top 26 mm (1") thick



Chamfered wood edging, 12mm (½")  
table top 26 mm (1") thick



Edge chamfered, 4 mm (5/32") radius  
table top 12 mm (½") thick

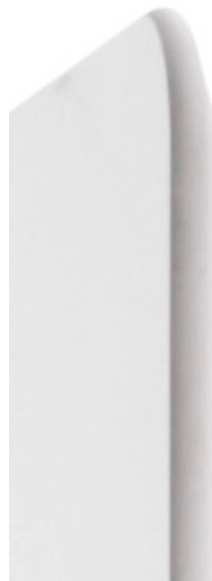



## From benches to room dividers to compartment-like options for deep work or meet-ups

The modular Insit Screens provide visual and acoustic privacy for any standalone bench or other configuration as required. To match the bench models, a set of stand-alone rear panels, L-shaped corner solutions, U-shaped panels that embrace the furniture on three sides and C-shaped enclosures check all the boxes. The total height of 135 cm provides effective screening, but can still be seen when people are standing up, so that the impression of the room is maintained.

All the screen modules are attached to the benches' seat frames using integrated tubular steel profiles. As a result, there's plenty of leg room, the floor underneath is easy to clean and the bench's floating appearance is maintained. What's more, this makes the modules easy to retrofit, remove and recombine, if spaces need to be reconfigured, or more face-to-face teamwork is required. Therefore, Insit Screen offers maximum flexibility to adapt to different demands.

Design: Wolfgang C.R. Mezger

Benches with high backrests, model 782/5, with C-shaped screen 781/20, at an Aline table, model 237/00, design: Andreas Störiko.



Flexible and easy to reconfigure: A pod enclosed by a C-shaped screen quickly becomes a standalone bench with a U-shaped screen if the large rear panel is removed and replaced by what was previously the side panel at the front.

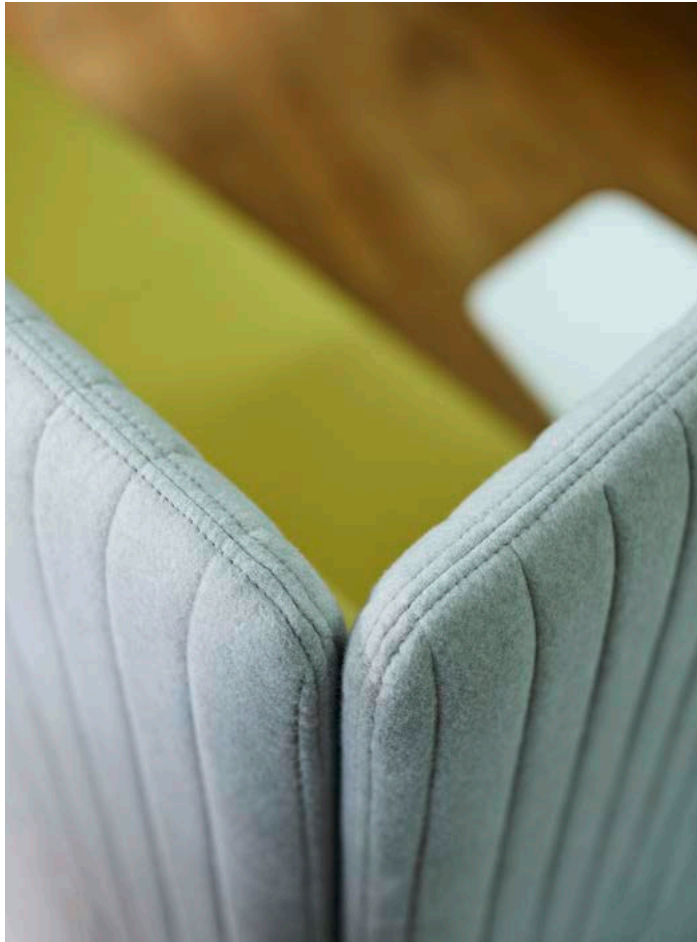

The screens' edges are all tapered to produce a very slim contour and the same goes for the way the rear and side panels are connected. This generates a softly rounded look to the outside and a curved miter-like joint on the inside. The striking double stitching on the fabric covers underscores the high-quality, precise craftsmanship. The rear- and side-panels are easy to adjust thanks to the leveling screws in the mount brackets.



The screens have a solid, spruce frame, which is fully upholstered. On the inside, an inlay of perforated hardboard absorbs sound.



A corner writing ledge can also be fitted to the side panels. When benches have open ends at the sides, a shelf can be slotted above the seat cushioning between the side panel and the seat.

# Insit Screens. 780 range. Examples.

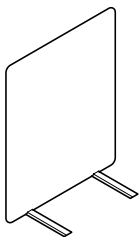

Rear panel, model 781/1

The purpose of the standalone rear panels, model 781/1, is to provide partial or full privacy for the various bench models at the rear. As a result, they are available in widths of 82.5 cm, 101.5 cm, 120 cm, 165 cm and 229 cm (32½", 40", 47¼", 65" and 90¾").

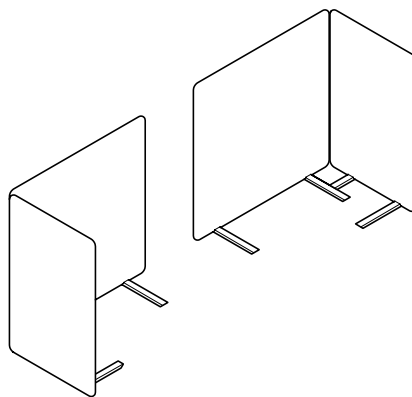

L-shaped screen, models 781/11 (on the left) and 781/12 (on the right)

The L-shaped screens consist of a rear panel that connects at an angle to a 64-cm-wide (25¼") side panel on the right (L-shaped screen model, right 781/11) or left (L-shaped screen model, left, 781/12) to the bench (when viewed by the user). The widths of the L-shaped screens' rear panels are the same as the standalone rear panels and, in the case of linear linkage options, can be added to these as desired. As a result, standalone benches can be screened off, or divided up to produce sectional seating.

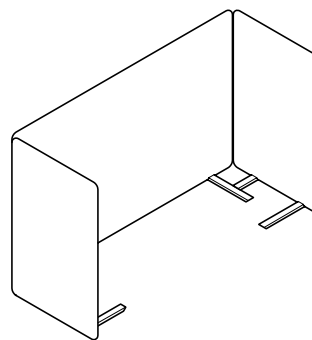

U-shaped screen, model 781/10

The U-shaped screen provides privacy for standalone benches at the rear and the two front sides. This transforms a bench into somewhere offering visual privacy. Just like the bench widths, the rear panels come in widths of 165 cm (65") (one component), 203 cm (79¾") (two components) and 240 cm (94½") (two components) and their tapered edges connect perfectly with the 64-cm-wide (25¼") side panels.

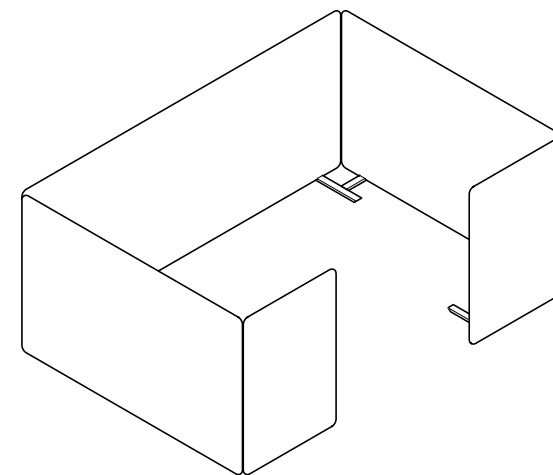

C-shaped screen, model 781/20

The C-shaped screen encloses two benches of equal width facing each other on 5 sides to form a compartment-like space. Just like the benches, the rear panels come in widths of 165 cm (65"), 203 cm (79¾") or 240 cm (94½") and the fronts have 64-cm-wide (25¼") side panels, while the width of the fully enclosed panel at the rear is 232.5 cm (91½"). This provides space for a table between the benches that is 70 cm (27½") in depth, which can be 70 cm (27½"), 140 cm (55½") or 175 cm (68¾") wide, depending on the width of the bench.

# Insit Screens. 780 range. Examples.

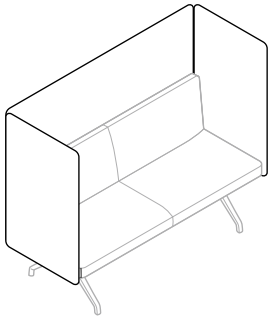

**780/10** U-shaped Screen with upholstered bench with backrest 782/5

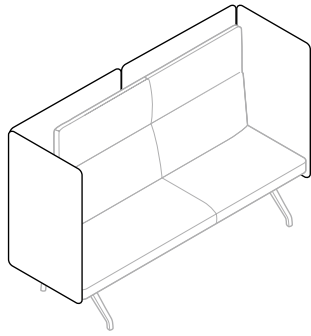

**781/10** U-shaped screen with upholstered bench with backrest 782/51

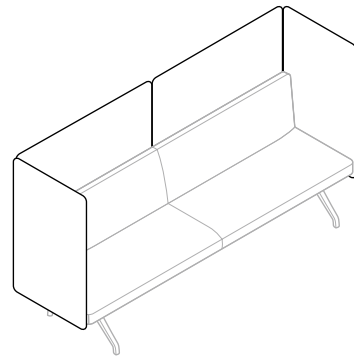

**781/10** U-shaped screen with upholstered bench with backrest 783/51

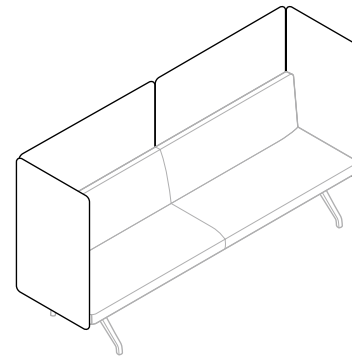

**781/10** U-shaped screen with upholstered bench with backrest 783/5

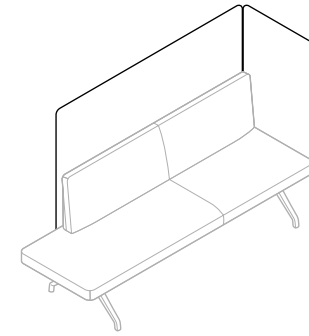

**781/12** L-shaped screen (on the left) with upholstered bench with backrest 782/51

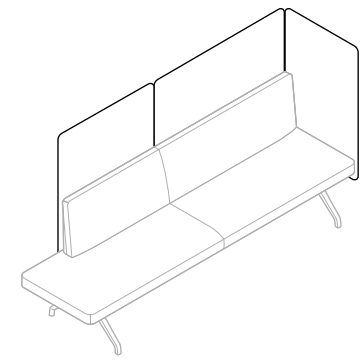

**781/12** L-shaped screen (on the left) with upholstered bench with backrest 783/51

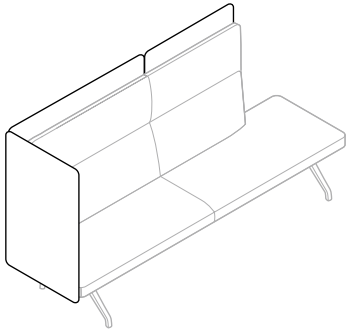

**781/11** L-shaped screen (on the right) with upholstered bench with backrest 783/52

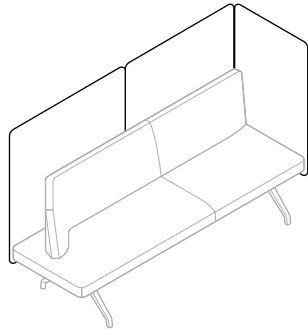

**781/12** L-shaped screen (on the left) with upholstered bench with backrest 782/52

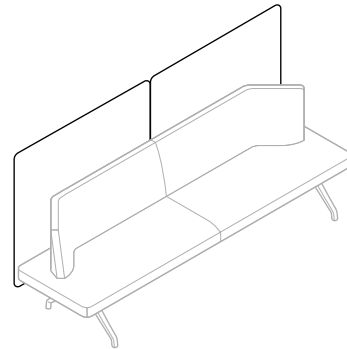

**781/1** Rear panel with upholstered bench with backrest 783/55

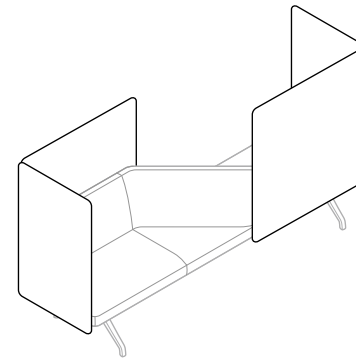

2 x **781/11** L-shaped screens (on the right) with upholstered bench with backrest 783/56

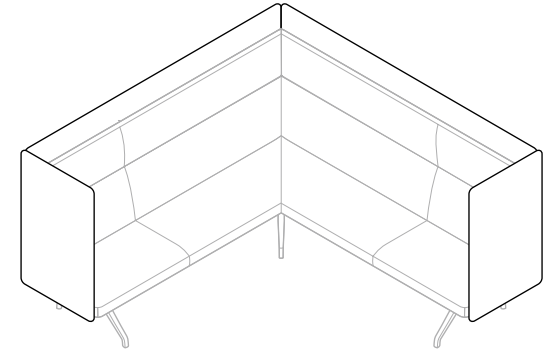

**781/11** L-shaped screen (on the right) and **781/12** L-shaped screen (on the left) with upholstered bench with backrest 782/90



# Insit Screens. 780 range. Examples.

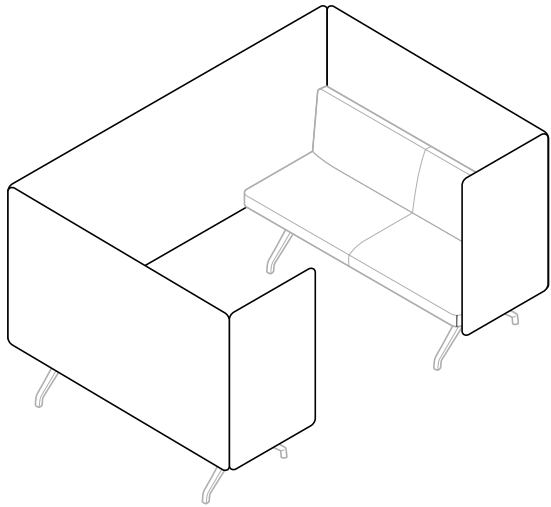

**781/20** C-shaped screen with upholstered benches with backrests 782/5

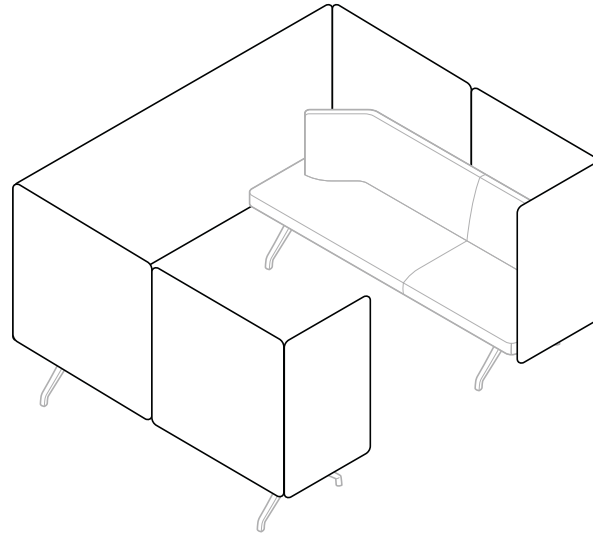

**781/20** C-shaped screen with upholstered benches with backrests 782/52

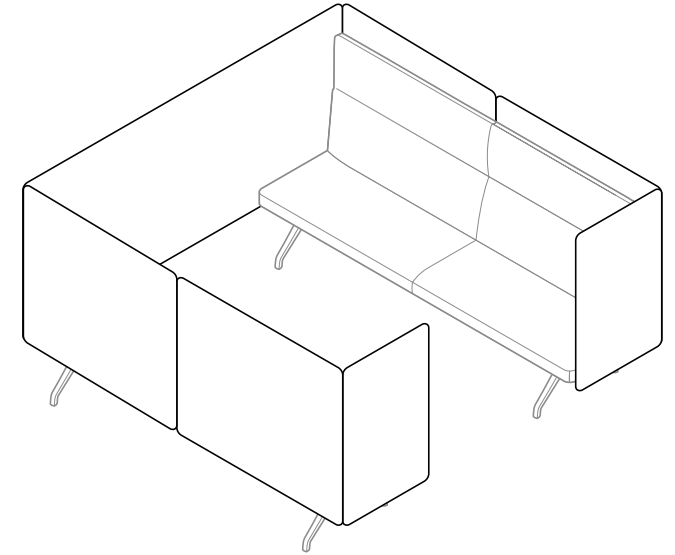

**781/20** C-shaped screen with upholstered benches with backrests 783/5, high backrest

# Insit table. 780 range. Accessories and other items.

# Wilkhahn



The Insit benches can be fitted with Insit Screen wall modules, but can also be linked with 64 cm (25¼") deep and optionally 32 cm (12½") or 64 cm (25¼") wide connecting tables in a linear or cornered manner to form sectional seating. In addition, 64 × 32 cm (25¼" × 12½") wide side tables can also be mounted at the front. If shelves (for options with open ends) or L-shaped corner writing ledges are required for benches with Insit Screen at the back and sides, these come in the form of slot-on modules (shelf 64 × 32 cm (25¼" × 12½"), corner writing ledge 60/20 cm × 40/15 cm (23⅝"/7⅞" × 15¾"/5⅞"), height 74 cm (29⅞").

# Insit table. 780 range. Accessories and other items.

# Wilkhahn

## Cable outlet



## Integrated techni-station Compact



## Installation frame



## Exchangeable ports



To fit to the connecting table mod. 780/10, to position in the middle.  
Die-cast zinc, matte chrome installation frame, round or square fitted installation to insert exchangeable ports.

Cable outlet

electricity supply

Wireless charging module  
(Qi standard)Port with  
2 x USB chargers

Insit can handle the requirements of any mobile working environments. High-quality cable outlets, in-built techni-stations, or a range of different connectors (for electricity, wireless charging, Keystone modules, or USB ports) can be fitted to the side and connecting tables, shelves and corner writing ledges.

# Insit table. 780 range. Accessories and other items.

# Wilkhahn

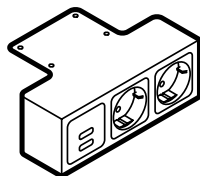

**701/94**  
Techni-station frame,

To mount under the seat,  
Sheet steel frame,  
coated black  
Socket strip with 3 modules:  
2 x power supply modules  
(When ordering, state local standard)  
1 x slot with 2 x USB ports (2.1 A  
charging current)  
to recharge up to two mobile devices  
with connection for a supply lead,  
model 708/8

If required or specified, sheet steel techni-stations coated black (2 modules for sockets, 1 module for 2 USB ports) are fitted underneath the seat and connected with suitable supply leads.



**708/8**  
Supply lead



Inline connectors with screws allow the benches and connecting table panels to be connected linearly or at the back.

**780**  
Inline connectors

Set for linear or back-to-back linkage of two benches without Insit Screen (one set is required for each bench connected)

**781**  
Inline connectors  
Set for linear connection of two benches each with a standalone Insit Screen rear panel (not possible with side panel linkage)

# Insit Details. 780 range. Accessories and other items.

# Wilkhahn

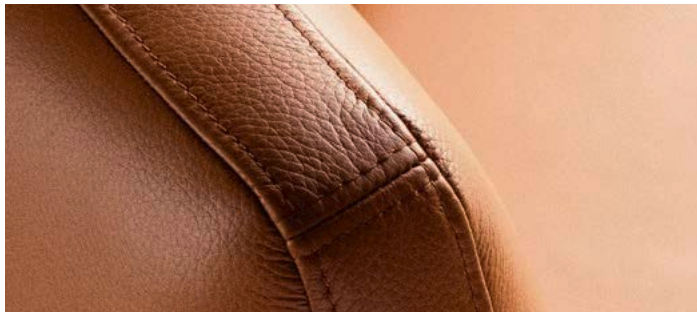

The details are equally as impressive as the form. The facings all the way around feature precise flat-felled seams, and the seams in the seat and backrest have decorative double saddle stitching.



The benches' fully upholstered seats and backrests are top quality, hard wearing, and designed for frequent use. They consist of solid beech frames with cut foam and cold foam upholstery, which has fleece overlay between the foam and the cover. This makes the furniture pleasant to sit on and protects the foam from mechanical wear and tear.



The high-quality craftsmanship continues in the base frames of the bench and the lounge table; made in one piece from die-cast aluminum that tapers at the bottom, they give the bench and the lounge table a stable yet elegant, floating look. Its lightweight appearance also pays off in terms of functionality – the area where feet are placed is unobstructed, making the furniture simple to grip and reposition as desired and the floor underneath easy to clean.



The design of the upholstery is based on the combination of geometrically clear lines and seat surfaces with the gentle and organic curves of the backrest.

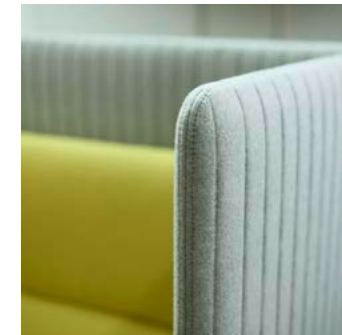

Hush Stripe 40, available exclusively for the screens, lends the panels a sculptural structure.

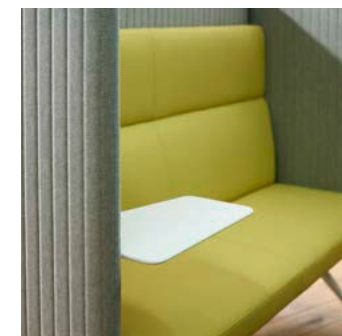

Depending on the perspective, the colors, surfaces and textures have a graphically appealing look.

# Insit. 780 range. Models and dimensions

# Wilkhahn

**782/5**  
Upholstered bench  
with backrest

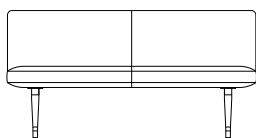
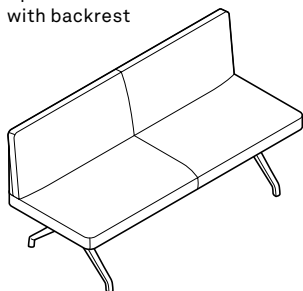

165 cm  
65"

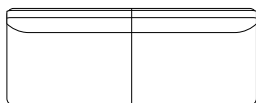

**782/5**

**783/5**  
Upholstered bench  
with backrest

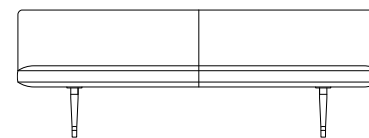
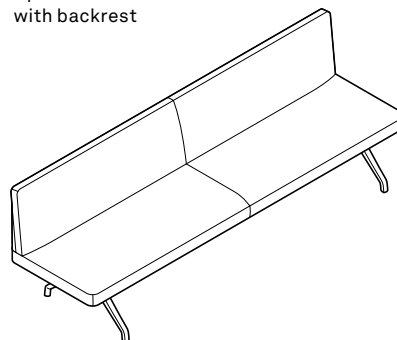

240 cm  
94 1/2"

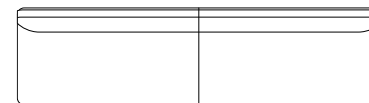

64 cm  
25 1/4"

**783/5**

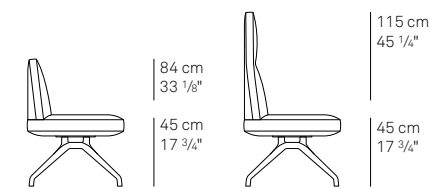

84 cm  
33 1/8"  
45 cm  
17 3/4"

115 cm  
45 1/4"

45 cm  
17 3/4"

64 cm  
25 1/4"

**782/5 and 783/5**

**782/6**  
Bench  
without backrest

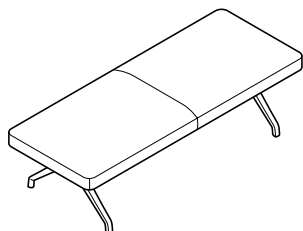

165 cm  
65"

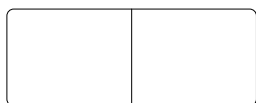

**782/6**

**783/6**  
Bench  
without backrest

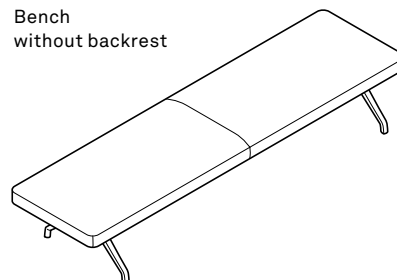

240 cm  
94 1/2"

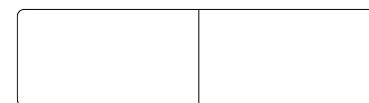

64 cm  
25 1/4"

**783/6**

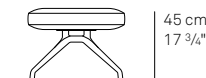

45 cm  
17 3/4"

64 cm  
25 1/4"

**782/6 and 783/6**

# Insit. 780 range. Models and dimensions

# Wilkhahn

**782/5** Upholstered bench with backrest with a U-shaped screen 781/10

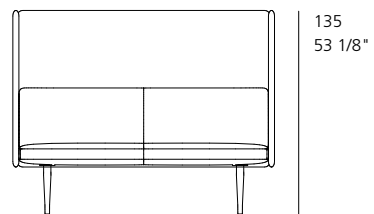
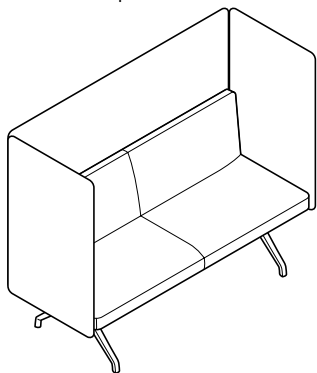

165  
64 15/16"

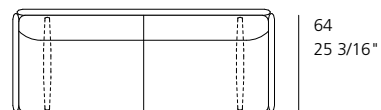

165  
64 15/16"

**783/5** Upholstered bench with backrest with a U-shaped screen 781/10

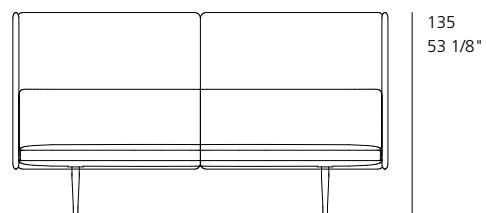
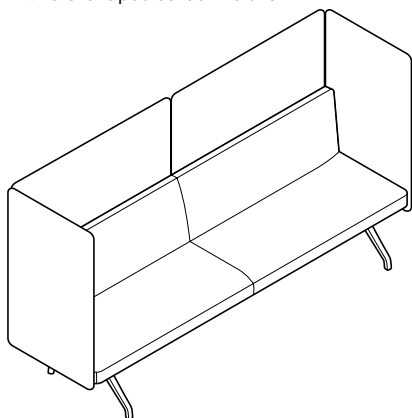

240  
94 1/2"

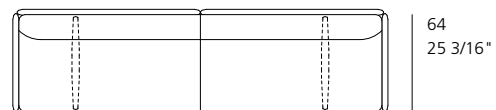

240  
94 1/2"

# Insit. 780 range. Models and dimensions

# Wilkhahn

**782/51**  
Upholstered bench  
with backrest

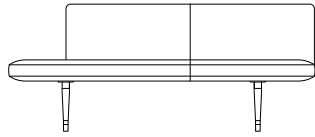
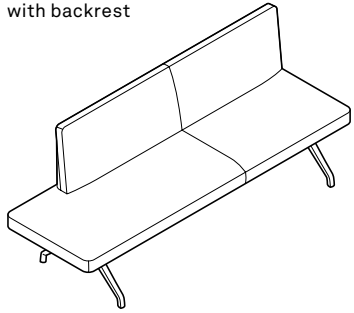

203 cm  
79 7/8"

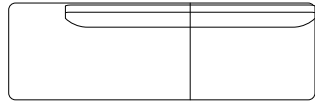

**782/51**

**783/51**  
Upholstered bench  
with backrest

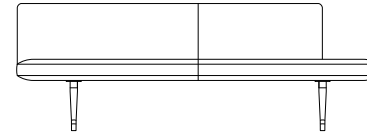
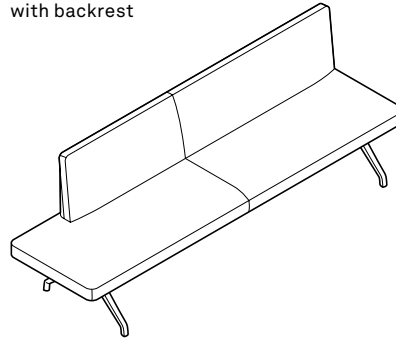

240 cm  
94 1/2"

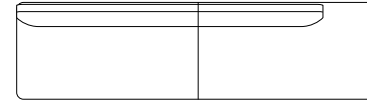

**783/51**

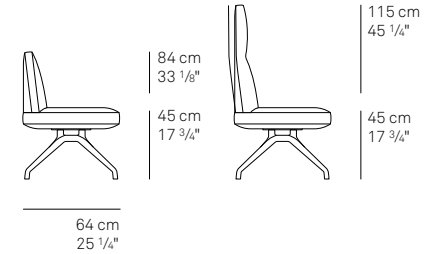

**782/51 and 783/51**

**782/52**  
Upholstered bench  
with backrest

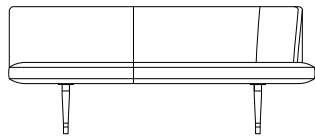
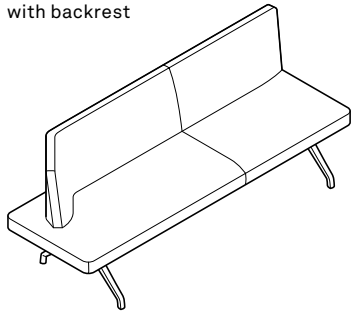

203 cm  
79 7/8"

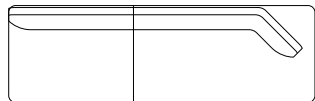

**782/52**

**783/52**  
Upholstered bench  
with backrest

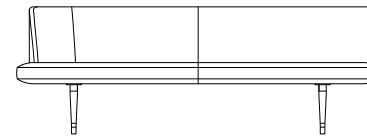
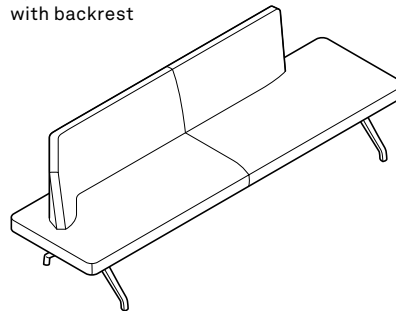

240 cm  
94 1/2"

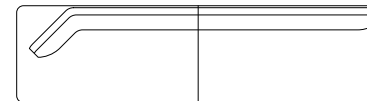

**783/52**

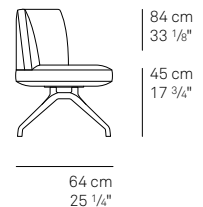

**782/52 and 783/52**



# Insit. 780 range. Models and dimensions

# Wilkhahn

**782/51** Upholstered bench with backrest with an L-shaped screen 781/12

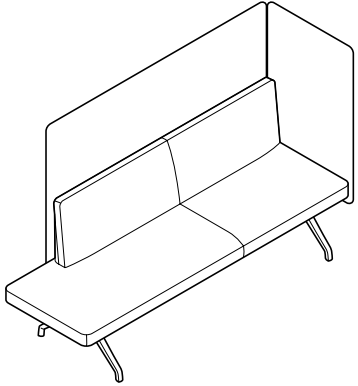

**783/51** Upholstered bench with backrest with an L-shaped screen 781/12

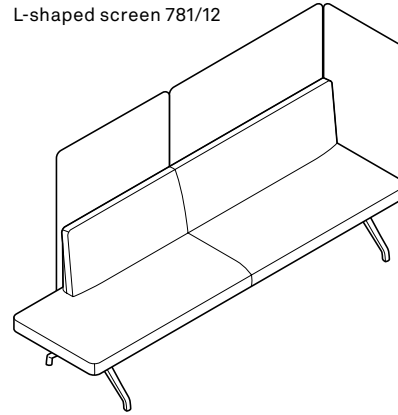

# Insit. 780 range. Models and dimensions

# Wilkhahn

**782/52** Upholstered bench with backrest with an L-shaped screen 781/12

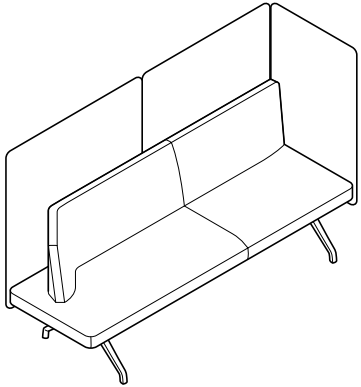

**783/52** Upholstered bench with backrest with an L-shaped screen 781/11

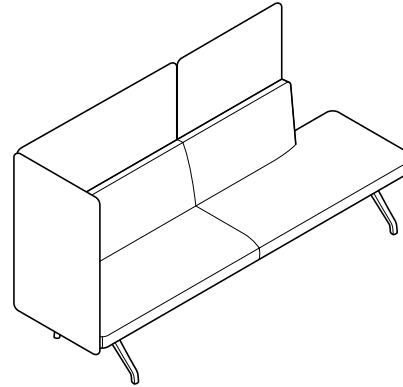

# Insit. 780 range. Models and dimensions

# Wilkhahn

**783/55**  
Upholstered bench  
with backrest

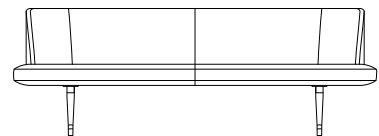
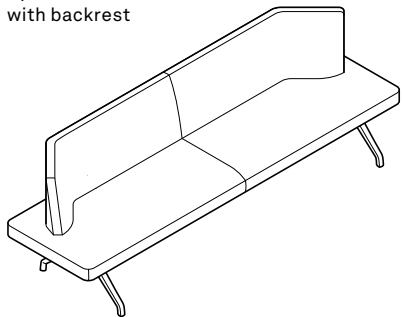

240 cm  
94 1/2"

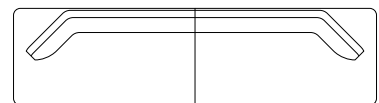

64 cm  
25 1/4"

**783/55**



84 cm  
33 1/8"

45 cm  
17 3/4"

64 cm  
25 1/4"

**783/56**  
Upholstered bench  
with backrest

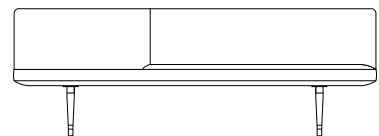
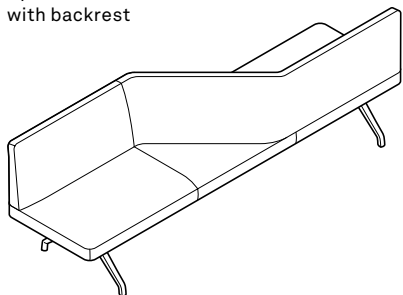

240 cm  
94 1/2"

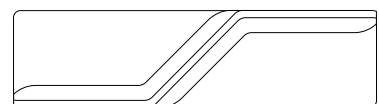

64 cm  
25 1/4"

**783/56**



84 cm  
33 1/8"

45 cm  
17 3/4"

64 cm  
25 1/4"

# Insit. 780 range. Models and dimensions

# Wilkhahn

**783/55** Upholstered bench with backrest and a standalone rear panel 781/1

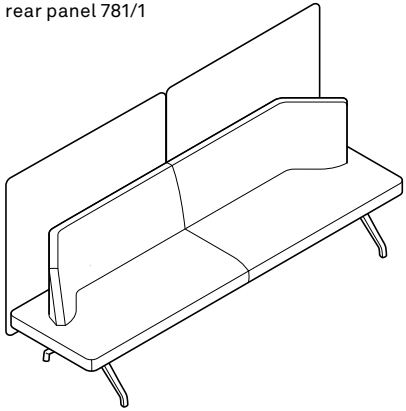

**783/56** Upholstered bench with backrest with L-shaped screens 781/11

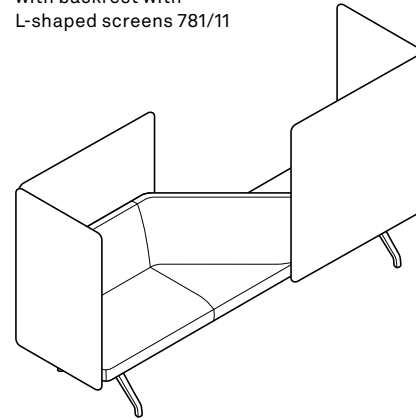

# Insit. 780 range. Models and dimensions

# Wilkhahn

**783/60**  
60° upholstered bench  
with backrest

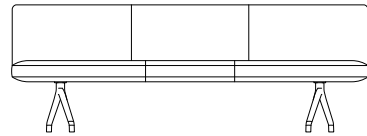
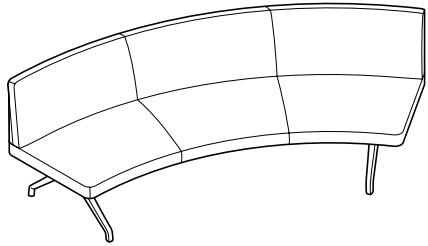

236 cm  
92 7/8"

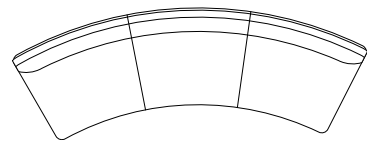

84 cm  
33 1/8"

**783/60**



84 cm  
33 1/8"  
45 cm  
17 3/4"

64 cm  
25 1/4"

**782/90**  
Corner element

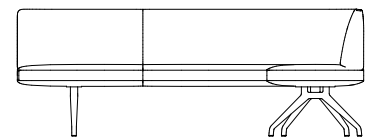
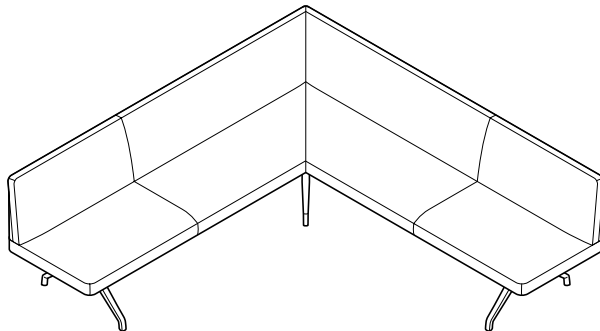

229  
90 3/16"

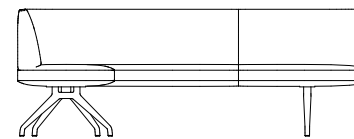

84  
33 1/16"  
45  
17 11/16"

229  
90 3/16"

**782/90**

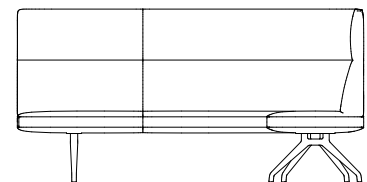

229  
90 3/16"

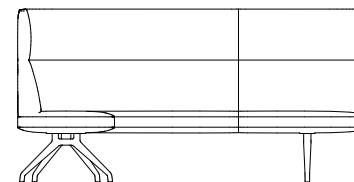

115  
45 1/4"  
45  
17 11/16"

229  
90 3/16"

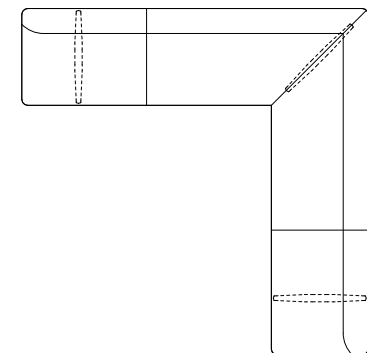

229  
90 3/16"

229  
90 3/16"

Subject to change.

# Insit. 780 range. Models and dimensions

**Wilkhahn**

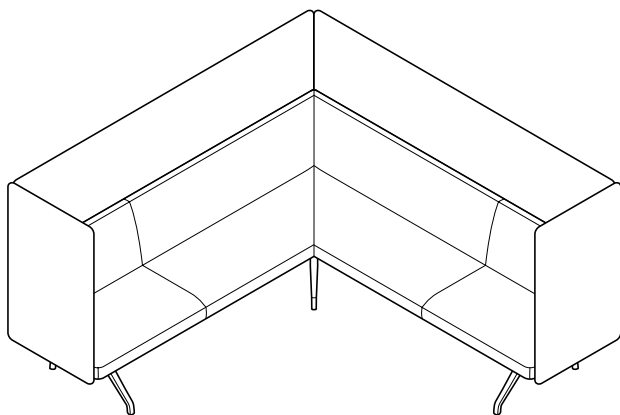

# Insit. 780 range. Models and dimensions

# Wilkhahn

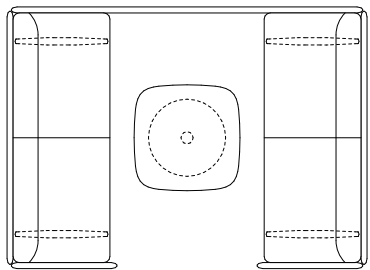
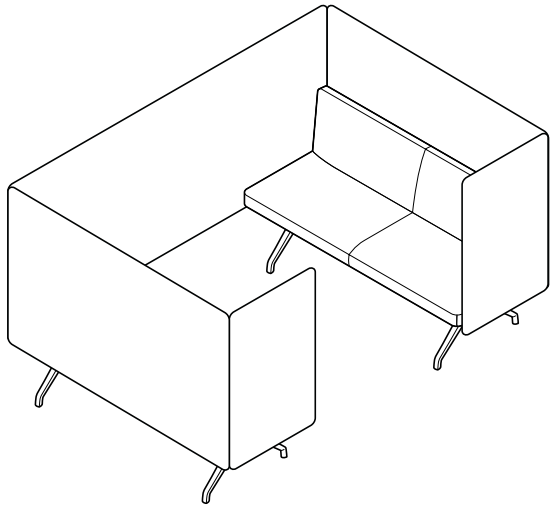

230  
90 9/16"

165  
64 15/16"

with table 780/2

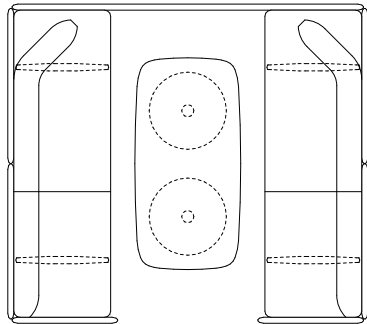
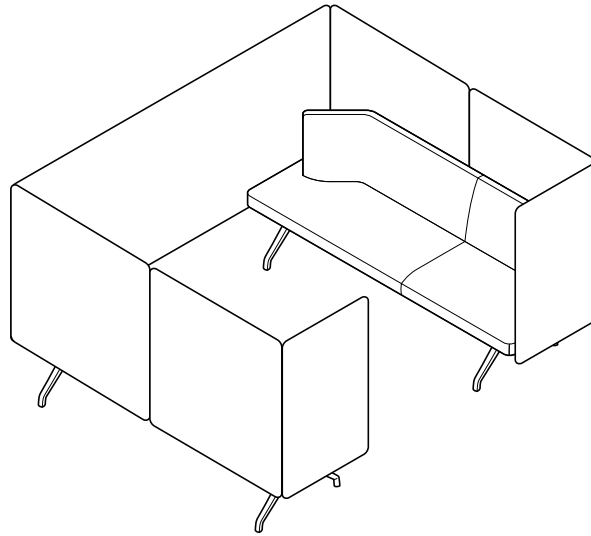

230  
90 9/16"

203  
79 15/16"

with table 780/4 (140 cm (55 1/8"))

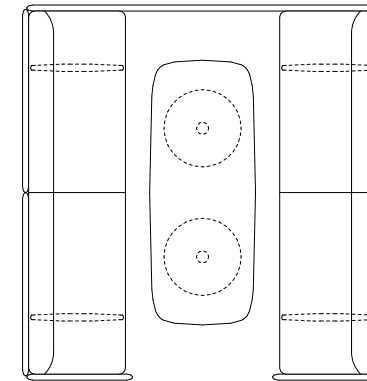
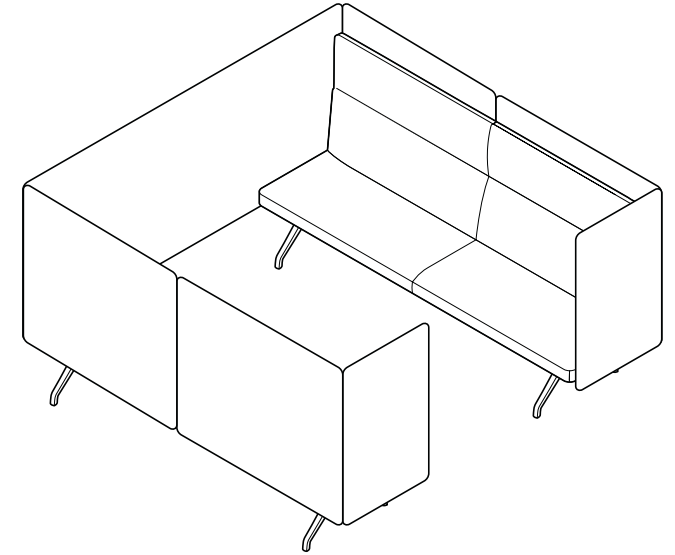

240  
94 1/2"

230

with table 780/4 (175 cm (68 7/8")) 90 9/16"

# Insit. 780 range. Models and dimensions

# Wilkhahn

**780/1**  
Round

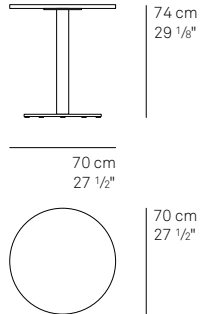
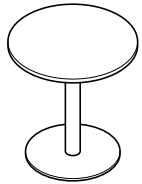

**780/1**

**780/3**  
Square

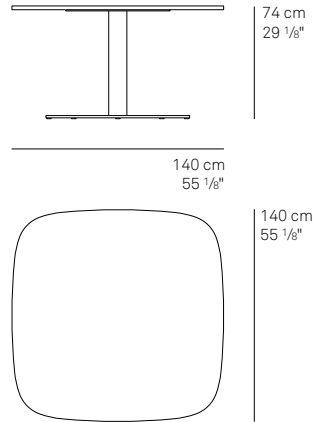
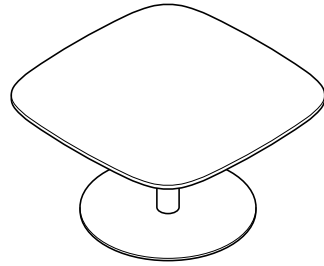

**780/3**

**780/9**  
Rectangular

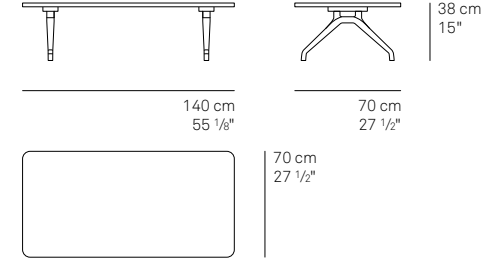
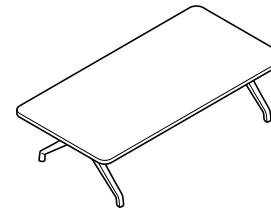

**780/9**

**780/2**  
Square

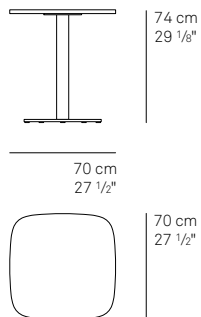
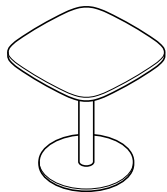

**780/2**

**780/4**  
Rectangular

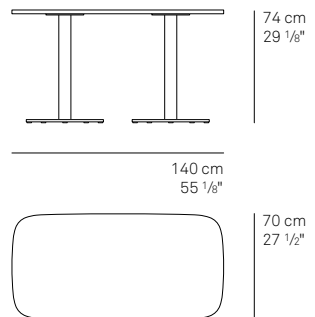
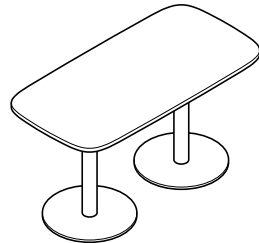

**780/4**

**780/4**  
Rectangular

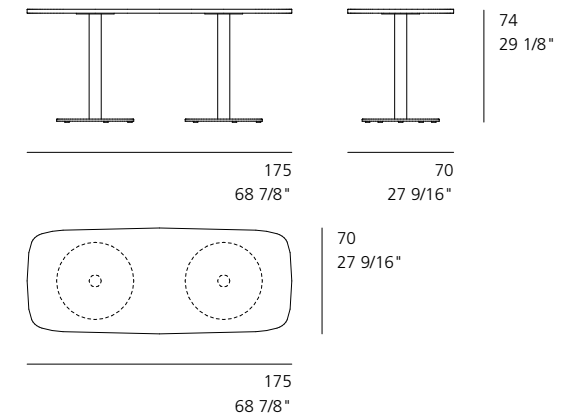
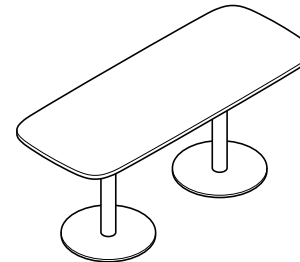

**780/4**

Subject to change.



# Insit. 780 range. Models and dimensions

# Wilkhahn

**780/10**  
Connecting table

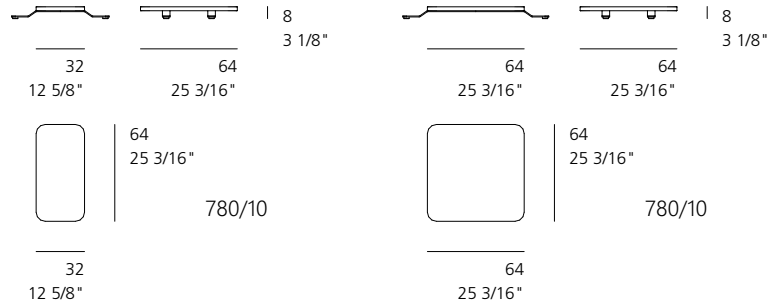
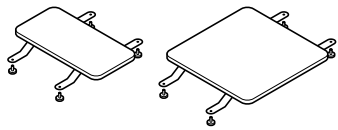

**780/13**  
Shelf

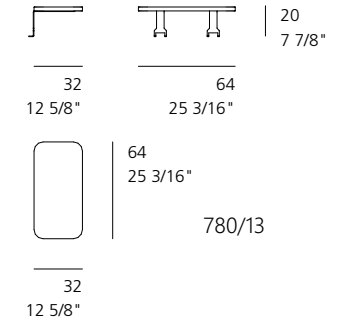
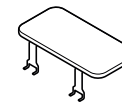

**780/11**  
Side table

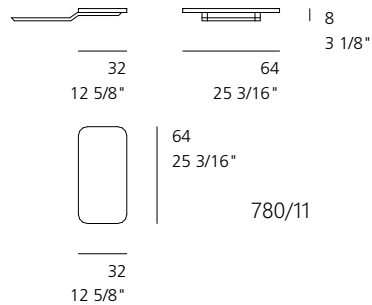
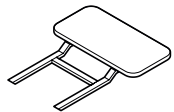

**780/14**  
Corner writing ledge

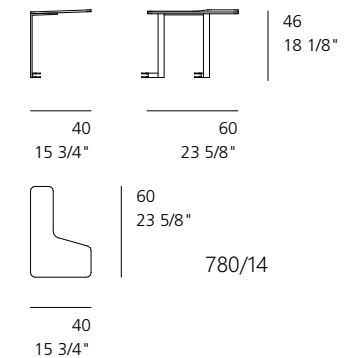
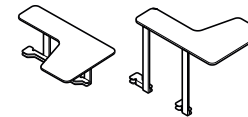

**780/12**  
Corner table

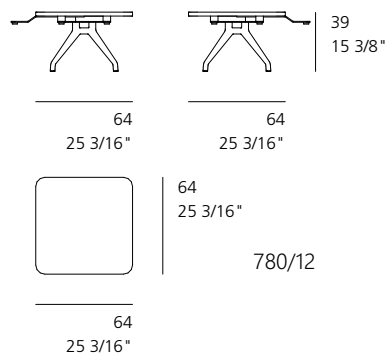
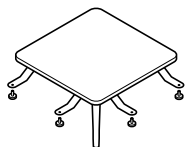

# Insit. 780 range. Technical details.

# Wilkhahn

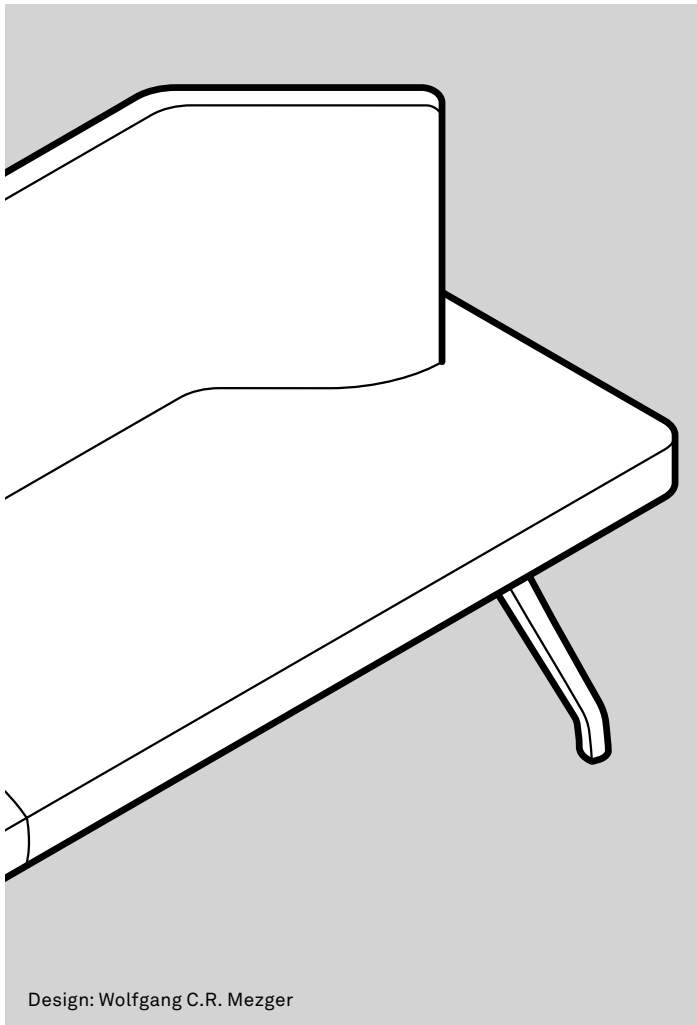

Design: Wolfgang C.R. Mezger

## Upholstered benches with backrests and benches without backrests

### Function

Multipurpose upholstered benches with and benches without backrests with coordinating tables for customer service areas, foyers, lobbies, waiting spaces, areas in the middle of rooms, cross-over spaces, co-working spaces and company restaurants. When sitting vertically at a seating height of 45 cm, people can work, communicate, eat and drink at normal table heights and chairs can be added. The integrative design turns each Insit into an individually scalable attractive sculpture. By using connectors and side tables, the elements create a versatile system that can be linked to form complex configurations. The range of two-, two-and-a-half and three-seaters includes benches that are straight sloping or linked at 90-degree angles at the corners and that come with linear backrests or ones curved on one or both sides or that change direction, as well as benches without backrests that can be used on both sides.

### Frame

Polished or high-luster polished die-cast aluminum A-line base frame or coated white, black or with a silver satin finish. Table top bearer to connect the seat made of black coated sheet steel. Black polyamide glides as the standard version for carpets; optionally with felt insert for hard flooring.

### Seat and backrest

Wooden frame design with integrated panel made of beech, upholstered all the way round with contour-cut foam, seat cushioning made of cold foam with a fleece overlay, fully covered in fabric or leather. Backrest: Wooden frame design made of beech, upholstered with contour-cut foam all the way round, back cushioning made of contour-cut foam, fully covered with fabric or leather, depending on the model linear, sloping or curved on one or both sides or with a change of direction, optional with a 30 cm higher backrest (only in linear models). Benches without backrests (models 782/6 and 783/6).

### Inline connectors

Models 780 set for linear, or back-to-back linkage of the benches (without rear panel and side panel screens) made of sheet steel, coated black, with four, black star-grip screws. (One set for each bench linked). Model 781 set for linear linkage of the benches (with rear panel screen connected, not possible with side panel) made of sheet steel, coated black, with four, black star-grip screws (one set for each bench linked).

### Screens (rear- and side-screens)

#### Function

Modular set of fully upholstered and covered stand-alone rear panels and combinations of rear- and side-panels to provide visual and acoustic privacy as required and to divide up stand-alone benches and linked items of sectional seating. Maximum flexibility in terms of functionality and uses because they can be retro-fitted and dismantled later on. Depending on the bench model, shelves and writing ledges can also be slotted/fitted on to provide privacy at the rear, or divide up seating at the rear and sides, all the way to privacy options for a sofa on three sides to allow deep work. Or C-shaped options with benches facing one another create a compartment-like booth.

# Insit. 780 range. Technical details.

# Wilkhahn

## Material

A solid pine structure with perforated acoustic fleece, fully upholstered with cut foam and covered. Tapered edges with double stitching all the way round for stylish linkage in a straight line or at an angle. In addition to the Insit upholstery materials and the Racer fabric group 37, also available with Hush Stripe 40 fabric with vertical stripes at 40 mm distance from one another.

## Clips

Linear and angular clips made of rectangular, tubular steel profiles, coated black, with integrated set screws to adjust the height.

## Tables, shelves and corner writing ledges

### Frames and clips

#### Models 780/1, 780/2, 780/3, 780/4

Steel disc base, (diameter models 780/1, 780/2 and 780/4 Ø 51 cm, model 780/3 Ø 95 cm) with cover made of sheet steel coated white, black or in a silver satin finish or optionally brushed stainless steel or bright chrome-plated. Steel table column to match the disc base with cover coated white, black or in a silver satin finish or optionally brushed or bright chrome-plated stainless steel. Sheet steel table top bearer, coated black.

#### Model 780/9

Polished or high-luster polished die-cast aluminum A-shaped base frame or coated white, black or with a silver satin finish. Table top bearer to connect the tabletop made of sheet steel coated black. Black polyamide glides as the standard version for carpets; optionally with felt insert for hard flooring.

## Models 780/10 and 780/12

Clips for the connecting tables linearly/at an angle with braces made of flat steel, coated black, with four handle screws for fixed linkage of tables and benches, model 780/12 additionally with A-shaped, diagonally aligned foot section made of die-cast aluminum, polished or high-luster polished, or in a white, black or silver satin finish. Table top bearer to connect the table top made of sheet steel coated black. Black polyamide glides as the standard version for carpets; optionally with felt insert for hard flooring.

#### Model 780/11

Clip for the side table with connecting profiles made of tubular steel coated black, to connect to the bench at the side.

#### Model 780/13

Clip for the shelf made of sheet steel coated black to slot between Insit Screen's rear and side panel.

#### Model 780/14

Clip for the corner writing ledge made of rectangular tubular steel profile, coated black, to place between the bench and Insit Screen's side panel.

## Core material of table top

Plywood with straight wood or plastic lipping all the way round or MDF table top with chamfered lipping all the way round

## Core material of corner writing ledge

Made of birch plywood, 12 mm thick, with straight edging, with laminate variant 1 and 2 or wood veneer, variant 1 and 2, or table top group 7 made of 12 mm solid-core HPL, chamfered edging.

## Table top group 1 – laminate

Table top thickness 26 mm table height 74.5 cm

### Variant 1

Laminate (single color) based on Wilkhahn's color and surface samples with straight wood edging or optionally bullnose (double) with impact-resilient profile (for an additional charge)

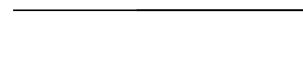

Straight wood lipping

Wood decor laminate from the Wilkhahn color and surface samples with straight, color-matched plastic edging

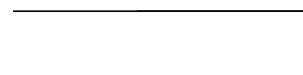

Straight plastic lipping

## Variant 2

Soft matte laminate from the Wilkhahn color and surface samples with straight wood lipping. Anti-reflective, soft-touch surface with anti-fingerprint characteristics.

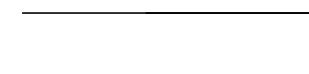

Straight wood lipping

## Table top group 2 – veneer

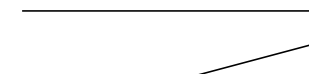

E2 – 5 chamfered wood lipping, 12 mm



Straight wood lipping

Table top thickness 26 mm table height 74.5 cm

## Variant 1

Beech, oak or ash veneer from Wilkhahn woodstain color samples with straight or chamfered wood lipping (at an extra charge).

## Variant 2

Maple, walnut or elm veneer from Wilkhahn woodstain color samples with straight or chamfered wood lipping (at an extra charge).

## Table top group 7 - black/white through-dyed

Table top thickness 12 mm table height 73 cm Table top made of through-dyed HPL (High Pressure Laminate) in black or white, chamfered lipping.

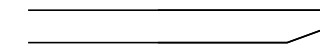

E5 – 1 HPL-solid-core, chamfered lipping, 4 mm radius

## Standards

The upholstered benches with and upholstered benches without backrests comply with the DIN EN 16139-L1 standard.

Subject to change.

# Insit. 780 range. Awards/ standards/ certificates.

# Wilkhahn

## Awards



reddot award 2019  
winner

## Product certificates/ product standards

The upholstered benches with and upholstered benches without backrests comply with the DIN EN 16139-L1 standard.

## Company's certificates, memberships



Mitglied der  
**DGNB**  
Deutsche Gesellschaft für Nachhaltiges Bauen  
German Sustainable Building Council



## Wilkhahn and sustainability

# Wilkhahn



In over 100 years of its corporate history, Wilkhahn can look back on a sustainability philosophy that has grown over decades. Aspects such as durability, social fairness, environmental responsibility and cultural orientation have been evolving as corporate principles since the 1950s. Wilkhahn today is regarded internationally as a model of excellence, not only on account of its products but also because of its modern corporate philosophy. This is because the company realized early on that sustainable design should embrace environmental aspects, improve social relationships and define the cultural role of a company. This approach to the way we do business creates a bond between us and our customers throughout the world. There is surely no more rewarding task than working together for a successful future that is worth living in.

📄 [Current sustainability report with environmental statement](#)



For further information please contact us!

# Wilkhahn



Wilkening + Hahne GmbH+Co.KG  
Fritz-Hahne-Str. 8  
31848 Bad Münde  
Germany  
Tel.: +49 5042 999-100  
[contact@wilkhahn.de](mailto:contact@wilkhahn.de)  
[www.wilkhahn.com](http://www.wilkhahn.com)



Roof of one of the four pavilions,  
which were designed by architect  
Frei Otto, on the Wilkhahn site.  
Photo: Klemens Ortmeier