

---

# BuzziCee

## Product Specification Sheet

---

This document contains technical information about the BuzziCee

---



[www.buzzi.space](http://www.buzzi.space)







## Centre of attention

Contrary to traditional seating elements, BuzziCee features a symmetrical curved shape that allows colleagues to hold informal meetings or to sit together apart. The unique acoustic seating element is designed to be the ultimate focal point in your workspace and acts as the perfect spot for gatherings whether it be in an open-plan office, reception area, hospitality space, or beyond. BuzziCee's striking design will instantly elevate your open area, all while absorbing excessive noise and creating a sense of togetherness.

Design by BuzziSpace Studio

---

## General

-  BuzziCee | BuzziCee Half
-  Upholstered acoustic foam seating element  
Fabrics: Fabric, Trevira CS+ | CS, Velvet, Remix 3, Clara 2, Hero 2, Tonus 4 or Memory 2
-  Dry Use
-  Assembled

---

## Acoustics



Absorption



Diffusion



Low Tone



Mid Tone



High Tone

---

## Content

Configurations	3
Components	4
Fabrics	6
Dimensions	8
Acoustics	9

# Configuration

---

## BuzziCee

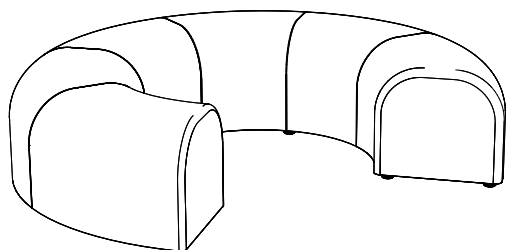

Upholstered acoustic foam seating element  
Fabric: Fabric, Trevira CS+ | CS, Velvet, Remix 3, Clara 2, Hero 2, Tonus 4 or Memory 2

Outer: Ø 193 cm | 75.98"  
Inner: Ø 93 cm | 36.61"  
Height: 46 cm | 18.11"

47 kg | 130.62 lbs

---

## BuzziCee Half

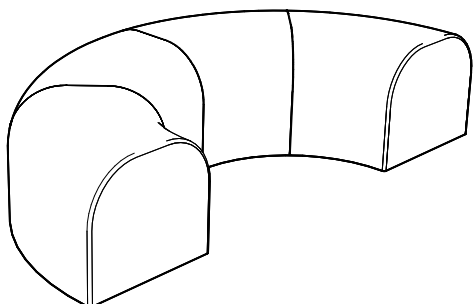

Upholstered acoustic foam seating element  
Fabric: Fabric, Trevira CS+ | CS, Velvet, Remix 3, Clara 2, Hero 2, Tonus 4 or Memory 2

Width: 193 cm | 75.98"  
Depth: 96,5 cm | 37.99"  
Height: 46 cm | 18.11"

30,5 kg | 67.24 lbs

# Components

---

## Plastic Feet



Bottom: Black fabric with plastic Feet

---

## Crocodile System



With the crocodile system located at the bottom, you can easily link various Cee and Cee Half elements together.

It also allows you to link a Cee or Cee Half with Planter 90 and Planter 90 Half.

---

## Inspiration Models

1x BuzziPlanter 90 Half  
1x BuzziCee Half



1x BuzziPlanter 90  
2x BuzziCee Half



1x BuzziPlanter 90  
1x BuzziCee  
2x BuzziCee Half



# Fabrics

---

## Fabric (45 colors)

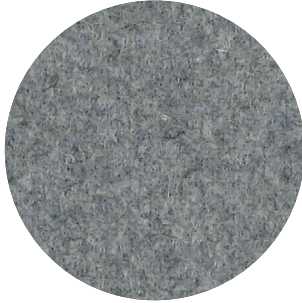

**Category A**

**Composition** 70% Recycled Wool, 25% Recycled Polyacryl,  
5% Recycled Other Fabrics

**Weight** 405 g/m<sup>2</sup> | 11.94 oz/yd<sup>2</sup>

**Abrasion resistance** 40.000 Martindale, 50,000 Wyzenbeek

**Flammability** EU: EN 1021.1/2006 | BS EN 1021.1/2006 (cigarette).  
EN 1021.2/2006 | BS EN 1021.2/2006 (match)  
USA: CAL TB 117 | ASTM E84 CLASS A

**Fastness to light** EU: 4 | USA 4

**Fastness to rubbing** EU: Wet 3-4 | Dry 4-5

**Fastness to crocking** USA: Wet 5 | Dry 5



## Trevira CS+ | CS (47 colors)

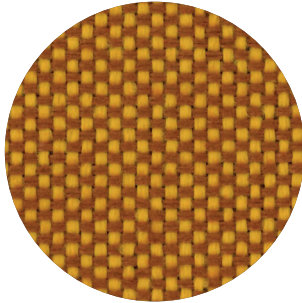

**Category A**

**Weight** 420 g/m<sup>2</sup> | 12.39 oz/yd<sup>2</sup>

**Composition** 100% Polyester, Trevira CS

**Abrasion resistance** 100.000 Martindale, 90,000 Wyzenbeek

**Flammability** BS 5852 part II: CRIB 5 | BS 7176 Medium Hazard  
USA: CAL TB 117 | M1 | B1 | EN 1021/1-2 | C1 |  
IMO Res. A652 (16)

**Fastness to light** EU: 6 | USA 5

**Fastness to rubbing** EU: Wet 4-5 | Dry 4-5

**Fastness to crocking** USA: Wet 5 | Dry 5



## Velvet (12 colors)

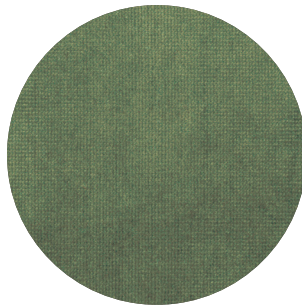

**Category B**

**Composition** 100% PES

**Weight** 375 g/m<sup>2</sup> | 11.06 oz/yd<sup>2</sup>

**Abrasion resistance** > 100.000 Martindale

**Fastness to light** EU: 4-5

**Fastness to rubbing** EU: Wet 4 | Dry 4-5

**Pilling** EU: 4-5

## Clara 2 (24 colors)

kvadrat

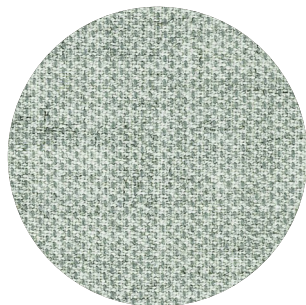

**Category B**

**Composition** 92% new wool, 8% nylon

**Weight** 400 g/lin.m

**Abrasion resistance** 80.000 Martindale rubs, EN ISO 12947

**Flammability** EN 1021-1/2 | BS 5852, ignition source 2-3 | DIN 4102 B2  
NF D 60 013 | UNI 9175 11M | US Cal. Tech. Bull. 117, Sec. E  
NFPA 260 | IMO A.652(16)

**Fastness to light** Note 5-7, ISO 105-B02

**Fastness to rubbing** (ISO) dry 4-5, wet 4

**Pilling** Note 4, EN ISO 12945



## Remix 3 (73 colors)

kvadrat



**Category B**

**Composition** 90% new wool, 10% nylon

**Weight** 415 g/lin.m

**Abrasion resistance** 100.000 Martindale rubs, EN ISO 12947

**Flammability** EN 1021-1/2 | BS 5852 part 1  
Önorm B1/Q1 | NF D 60 013 | UNI 9175, 11M  
AS/NZS 1530.3 | Cal. Tech. Bull. 117-2013  
NFPA 260 | IMO FTP Code 2010:Part 8

**Fastness to light** Note 5-7, ISO 105-B02

**Fastness to rubbing** (ISO) dry 4-5, wet 4

**Pilling** Note 4, EN ISO 12945



## Hero 2 (33 colors)

kvadrat

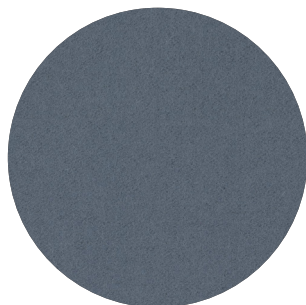

**Category C**

**Composition** 97% new wool, 3% nylon

**Weight** 580 g/lin.m

**Abrasion resistance** 45.000 Martindale rubs, EN ISO 12947

**Flammability** EN 1021-1/2 | DIN 4102 B2 | NF D 60 013  
UNI 9175 11M | US Cal. Bull. 117-2013 | NFPA 260  
IMO A.652 (16)

**Fastness to light** Note 5-6, ISO 105-B02

**Fastness to rubbing** (ISO) dry 4-5, wet 4-5

**Pilling** Note 3-4, EN ISO 12945



## Tonus 4 (47 colors)

kvadrat



**Category** D

**Composition** 90% new wool, 10% Helanca

**Weight** 665 g/lin.m

**Abrasion resistance** 100.000 Martindale rubs, EN ISO 12947

**Flammability** EN 1021-1/2 | BS 5852 part 1 | DIN 4102 B2

Önorm B1/Q1 | NF D 60 013 | UNI 9175 11M

US Cal. Bull. 117-2013 | NFPA 260 | IMO A.652 (16)

**Fastness to light** Note 5-7, ISO 105-B02

**Fastness to rubbing** (ISO) dry 3-5, wet 3-5

**Pilling** Note 3, EN ISO 12945



## Memory 2 (20 colors)

kvadrat

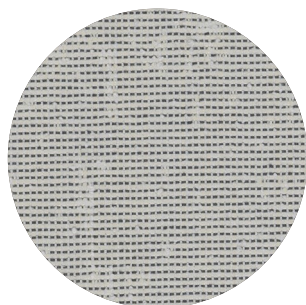

**Category** E

**Composition** 100% Trevira CS

**Weight** 700 g/lin.m

**Abrasion resistance**

35.000 rubs acc. to the Martindale method, EN ISO 12947

**Flammability** EN 1021-1/2 | DIN 4102 B1 | Önorm B1/Q1

NF D 60 013 | NF P 92 507 M1 | UNI 9175 11M

UNI 9177 classe 1 | US Cal. Tech. Bull. 117

IMO A.652 (16)

**Fastness to light** Note 5-8, ISO 105-B02

**Fastness to rubbing** (ISO) dry 4-5, wet 4-5

**Pilling** Note 4, EN ISO 12945





# Dimensions

## BuzziCee

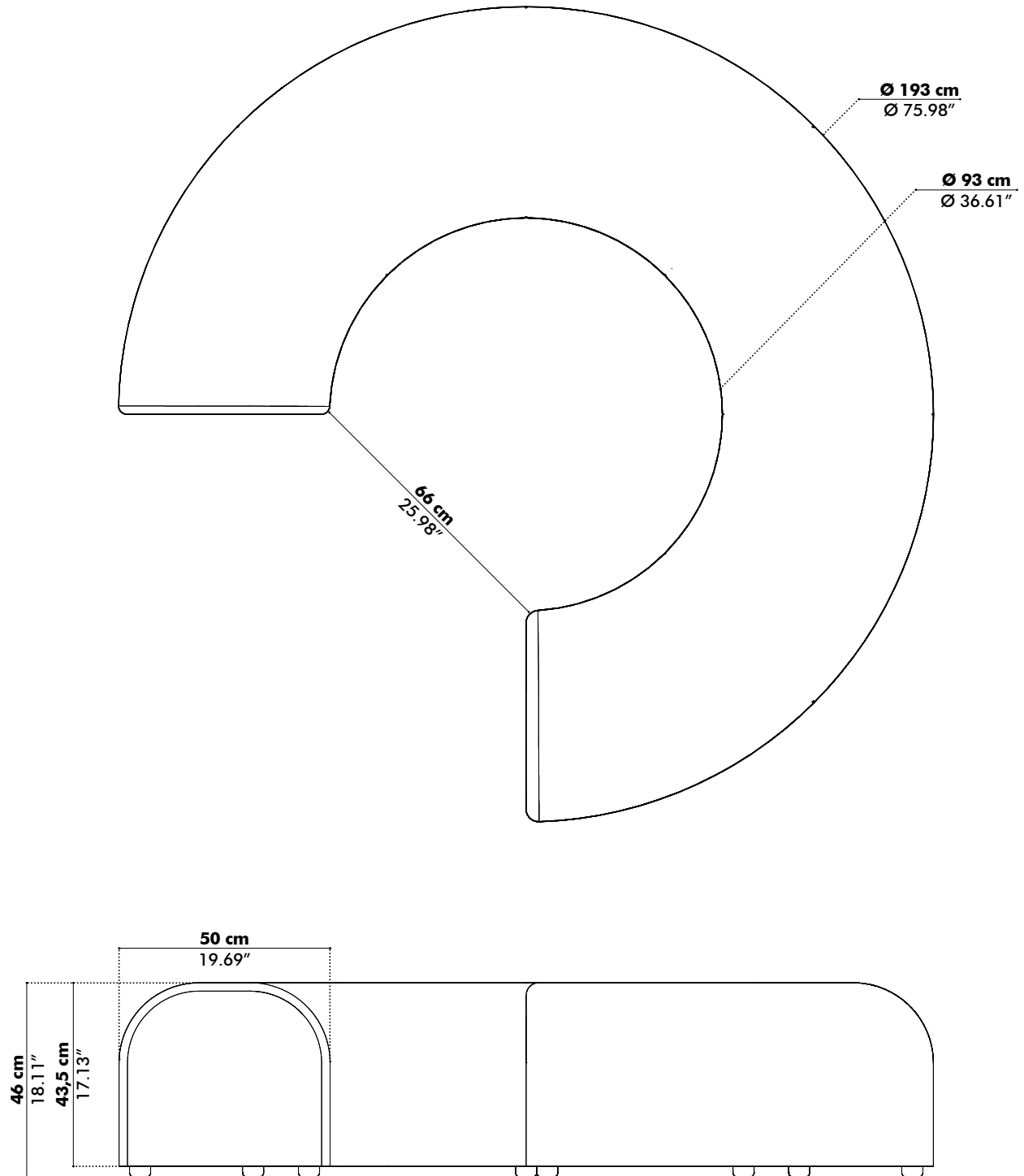

# BuzziCee Half

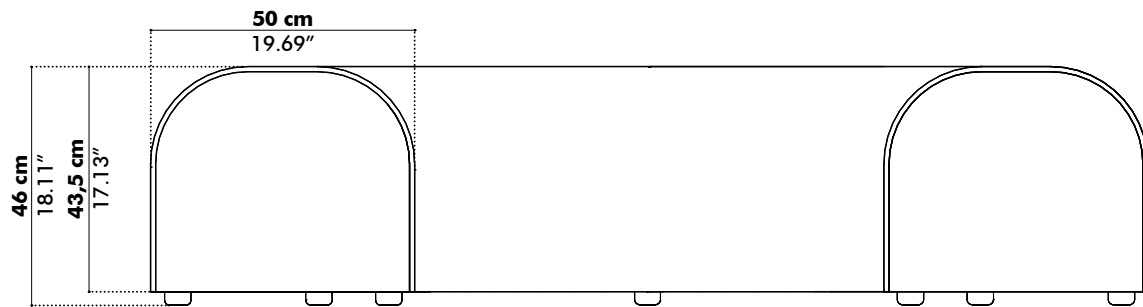
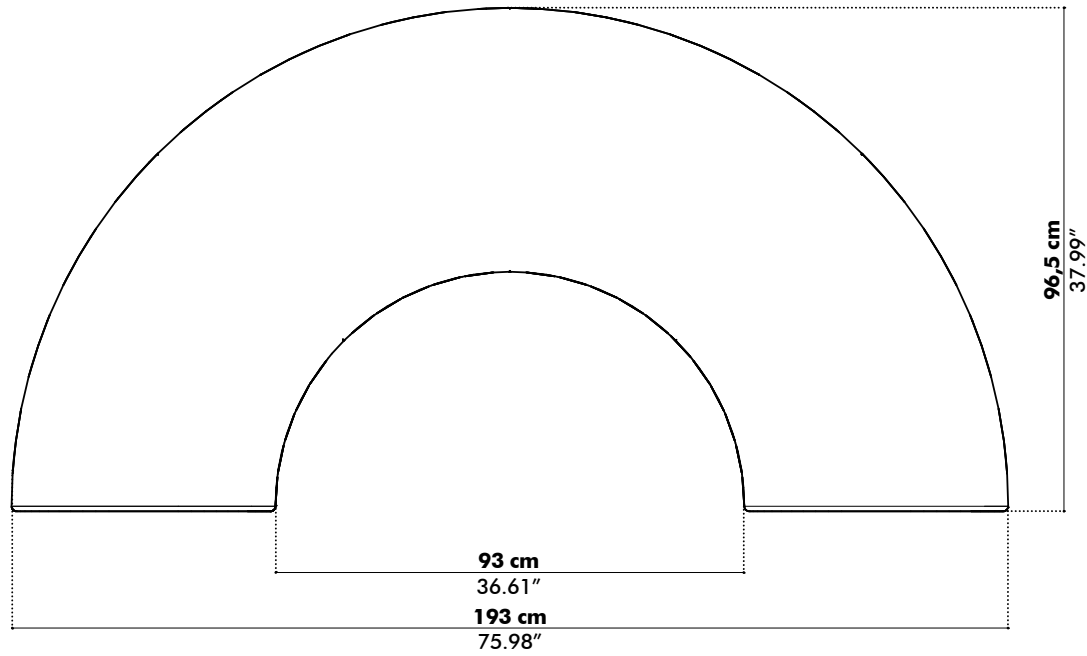

# Acoustics

---

## BuzziCee

Equivalent sound absorption area in m<sup>2</sup> per object

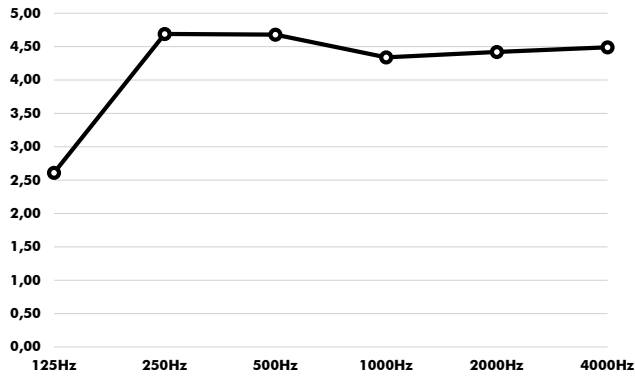

Hz	Aeq/m <sup>2</sup>
125	2.61
250	4.69
500	4.68
1000	4.34
2000	4.42
4000	4.49